

Software Developer's Manual

ESC/P Command Reference

RJ-4230B/4250WB

RJ-3230B/3250WB

RJ-2030/2050/2140/2150

TD-4410D/4420DN/4510D/4520DN/4550DNWB/4210D

TD-2020/2120N/2130N

Version 3.02

The Brother logo is a registered trademark of Brother Industries, Ltd.

Brother is a registered trademark of Brother Industries, Ltd.

© 2021 Brother Industries, Ltd. All rights reserved.

The Bluetooth word mark and logos are owned by the Bluetooth SIG, Inc. and, any use of such marks by Brother Industries, Ltd. is under license.

Zebra, ZPL and ZPL II are registered trademarks of ZIH Corporation.

BarStar Pro Encode Library (PDF417, Micro PDF417, DataMatrix, MaxiCode, AztecCode, GS1 Composite, GS1 Databar, Code93, MSI/Plessey, POSTNET, Intelligent Mail Barcode)
Copyright (c) 2007 AINIX Corporation. All rights reserved.

QR Code is registered trademark of DENSO WAVE INCORPORATED.

QR Code Generating Program Copyright © 2008 DENSO WAVE INCORPORATED

Epson ESC/P is a registered trademark of Seiko Epson Corporation.

Portions of this software are copyright © 2014 The FreeType Project (www.freetype.org). All rights reserved.

Each owner whose software title is mentioned in this document has a Software License Agreement specific to its proprietary programs.

Any trade names and product names of companies appearing on Brother products, related documents and any other materials are all trademarks or registered trademarks of those respective companies.

IMPORTANT - PLEASE READ CAREFULLY

Note

This documentation ("Documentation") provides information that will assist you in controlling your Printer (Please refer to "[Appendix A: Supported Printers](#)").

You may use the Documentation only if you first agree to the following conditions.

If you do not agree to the following conditions, you may not use the Documentation.

Condition of Use

You may use and reproduce the Documentation to the extent necessary for your own use of your Printer Model ("Purpose"). Unless expressly permitted in the Documentation, you may not;

- (i) copy or reproduce the Documentation for any purpose other than the Purpose,
- (ii) modify, translate or adapt the Documentation, and/or redistribute it to any third party,
- (iii) rent or lease the Documentation to any third party, or,
- (iv) remove or alter any copyright notices or proprietary rights legends included within the Documentation.

No Warranty

- a. Any updates, upgrades or alteration of the Documentation or Printer Model will be performed at the sole discretion of Brother. Brother may not respond to any request or inquiry about the Documentation.
- b. THIS DOCUMENTATION IS PROVIDED TO YOU "AS IS" WITHOUT WARRANTY OF ANY KIND, WHETHER EXPRESS OR IMPLIED, INCLUDING, BUT NOT LIMITED TO, THE IMPLIED WARRANTY OF FITNESS FOR A PARTICULAR PURPOSE. BROTHER DOES NOT REPRESENT OR WARRANT THAT THIS DOCUMENTATION IS FREE FROM ERRORS OR DEFECTS.
- c. IN NO EVENT SHALL BROTHER BE LIABLE FOR ANY DIRECT, INDIRECT, PUNITIVE, INCIDENTAL, SPECIAL OR CONSEQUENTIAL DAMAGES OR ANY DAMAGES WHATSOEVER, ARISING OUT OF THE USE, INABILITY TO USE, OR THE RESULTS OF USE OF THE DOCUMENTATION OR ANY SOFTWARE PROGRAM OR APPLICATION YOU DEVELOPED IN ACCORDANCE WITH THE DOCUMENTATION.

Contents

| | |
|---|-----------|
| Introduction | 1 |
| What is ESC/P? | 2 |
| 1. Using ESC/P Commands | 3 |
| 2. Examples of Using ESC/P Commands | 5 |
| 3. ESC/P Command Limitations | 11 |
| 3.1 Print area..... | 11 |
| 3.2 Characters..... | 13 |
| 3.2.1 Character sizes..... | 13 |
| 3.2.2 Character pitches | 14 |
| 3.3 Print position..... | 15 |
| 3.3.1 Characters..... | 15 |
| 3.3.2 Bitmaps, barcodes and downloaded images | 15 |
| 3.4 Line feed amount..... | 16 |
| 4. Control Code List | 17 |
| 5. Control Command Details | 21 |
| 5.1 Character/style selection commands..... | 21 |
| ESC R Select international character set | 21 |
| ESC q Select character style | 22 |
| ESC k Select font..... | 23 |
| ESC t Select character code set | 25 |
| 5.2 Text printing commands..... | 26 |
| ESC 4 Apply italic style | 26 |
| ESC 5 Cancel italic style | 26 |
| ESC E Apply bold style | 27 |
| ESC F Cancel bold style | 27 |
| ESC G Apply double-strike printing | 28 |
| ESC H Cancel double-strike printing | 28 |
| ESC P Apply pica pitch (10 cpi)..... | 29 |
| ESC M Apply elite pitch (12 cpi)..... | 31 |
| ESC g Apply micron pitch (15 cpi) | 32 |
| ESC p Specify proportional characters | 33 |
| ESC W Specify double-width characters | 33 |
| SO Specify auto-canceling stretched characters | 34 |
| ESC SO Specify auto-canceling stretched characters | 34 |
| SI Specify compressed characters..... | 35 |
| ESC SI Specify compressed characters..... | 35 |
| DC2 Cancel compressed characters | 36 |
| DC4 Cancel auto-canceling double-width characters | 36 |
| ESC – Apply/cancel underlining..... | 37 |
| ESC ! Global formatting | 38 |
| ESC SP Specify character spacing..... | 39 |
| ESC X Specify character size..... | 40 |
| 5.3 Line feed commands | 41 |
| ESC 0 Specify line feed of 1/8 inch..... | 41 |
| ESC 2 Specify line feed of 1/6 inch..... | 41 |
| ESC 3 Specify minimum line feed..... | 42 |
| ESC A Specify line feed of n/60 inch..... | 42 |
| 5.4 Horizontal movement commands | 43 |
| ESC I Specify left margin | 43 |
| ESC Q Specify right margin..... | 45 |

| | | |
|--------------------------------------|---|-----|
| CR | Carriage return | 46 |
| ESC D | Specify horizontal tab position | 47 |
| HT | Perform horizontal tab | 48 |
| ESC \$ | Specify absolute horizontal position | 49 |
| ESC \ | Specify relative horizontal position | 49 |
| ESC a | Specify alignment | 50 |
| 5.5 Vertical movement commands | | 51 |
| LF | Line feed | 51 |
| FF | Page feed | 51 |
| ESC J | Forward paper feed | 52 |
| ESC B | Specify vertical tab position | 53 |
| VT | Perform vertical tab | 54 |
| ESC (V | Specify absolute vertical position | 55 |
| ESC (v | Specify relative vertical position | 56 |
| 5.6 Paper formatting commands | | 57 |
| ESC (c | Specify page format | 57 |
| ESC (C | Specify page length | 58 |
| 5.7 Printer control commands | | 59 |
| ESC @ | Initialize | 59 |
| ESC i U x | Reboot | 60 |
| 5.8 Graphics commands | | 61 |
| ESC * | Select bit image <for 203dpi printers> | 61 |
| ESC * | Select bit image <for 300dpi printers> | 65 |
| ESC K | 8-dot single-density bit image | 71 |
| ESC L | 8-dot double-density bit image | 71 |
| ESC Y | 8-dot double-speed double-density bit image | 72 |
| ESC Z | 8-dot quadruple-density bit image | 72 |
| 5.9 Advanced commands | | 73 |
| ESC i B | Barcode | 73 |
| ESC i Q | 2D barcode (QR Code) | 78 |
| ESC i P | QR Code version | 81 |
| ESC i V | 2D barcode (PDF417) | 82 |
| ESC i D | 2D barcode (DataMatrix) | 85 |
| ESC i M | 2D barcode (MaxiCode) | 88 |
| ESC i J | 2D barcode (Aztec) | 90 |
| ESC i G | Specify font | 92 |
| ESC i F P | Print downloaded data | 93 |
| ESC i a | Switch command mode | 97 |
| ESC i S | Status information request | 98 |
| ESC i L | Specify landscape orientation | 102 |
| ESC i C | Specify cutting | 103 |
| ESC i H | Specify recovery setting | 103 |
| 5.10 Advanced static commands | | 104 |
| ESC iXQ2 | Select default character style | 104 |
| ESC iXQ1 | Retrieve default character style | 104 |
| ESC iXk2 | Select default font | 105 |
| ESC iXk1 | Retrieve default font | 106 |
| ESC iXX2 | Specify default character size | 107 |
| ESC iXX1 | Retrieve default character size | 107 |
| ESC iX32 | Specify default line feed | 108 |
| ESC iX31 | Retrieve default line feed | 108 |
| ESC iXA2 | Select default alignment | 109 |
| ESC iXA1 | Retrieve default alignment | 109 |
| ESC iX(2 | Specify default page length | 110 |
| ESC iX(1 | Retrieve default page length | 110 |

| | | |
|--|--|------------|
| ESC iXL2 | Select default landscape orientation | 111 |
| ESC iXL1 | Retrieve default landscape orientation..... | 111 |
| ESC iXj2 | Select default international character set..... | 112 |
| ESC iXj1 | Retrieve default international character set | 113 |
| ESC iXm2 | Select default character code set | 114 |
| ESC iXm1 | Retrieve default character code set | 114 |
| ESC iXd2 | Specify recovery setting..... | 115 |
| ESC iXd1 | Retrieve recovery setting | 115 |
| ESC iXv2 (0Ch) | Specify recovery count | 116 |
| ESC iXv1 (0Ch) | Retrieve recovery count..... | 117 |
| ESC iXE2 | Specify barcode margin setting | 118 |
| ESC iXE1 | Retrieve barcode margin setting..... | 118 |
| ESC iX_2 (00h) | Specify line print setting | 119 |
| ESC iX_1 (00h) | Retrieve line print setting | 119 |
| ESC iX_2 (01h) | Specify line print timeout setting | 120 |
| ESC iX_1 (01h) | Retrieve line print timeout setting..... | 120 |
| ESC i DC1 SQ(01h) | Specify self-printing QR code content..... | 121 |
| ESC i DC1 SQ(00h) | Retrieve self-printing QR code content | 121 |
| ESC i DC1 SR(01h) | Select setting change lock..... | 122 |
| ESC i DC1 SR(00h) | Retrieve setting change lock | 122 |
| Appendix A: Supported Printers | | 123 |
| Appendix B: Specifications | | 124 |
| Appendix C: Character Code Tables | | 129 |
| Character code tables | | 129 |
| International character set table | | 133 |
| Appendix D: Introducing the Brother Developer Center..... | | 134 |

Introduction

This material provides the necessary information for directly controlling your printer.

This information is provided assuming that the user has full understanding of the operating system being used and basic mastery of communication interfaces in a developer's environment.

Read the model names that appear in the screens in this manual as the name of your printer.

We accept no responsibility for any problems caused by programs that you develop using the information provided in this material, affecting software, data or hardware, including the printer, and any problems resulting directly or indirectly from them. Use this material only if you accept these terms.

This material shall not be reproduced, in part or in full, without prior approval. In addition, this material shall not be used as evidence in a lawsuit or dispute in a way that is unfavorable towards our company.

These ESC/P commands have been adapted specifically for this company.

What is ESC/P?

ESC/P is one type of control codes used for printers. With the codes introduced in this document, various labels can be created and printed. In this document, ESC/P codes are provided as both ASCII and binary codes.

When sending codes to the printer, make sure that the binary codes are used, otherwise the printer cannot parse the codes.

1. Using ESC/P Commands

Below is a description of the flow for creating documents.

Also refer to "[2. Examples of Using ESC/P Commands](#)".

(1) Start ESC/P

- | | |
|-----------------------------|--|
| 1. Switch the command mode. | - Switch command mode (ESC i a 0) Note: ESC/P mode |
| 2. Initialize | - Initialize (ESC @) |



(2) Format settings

- | | |
|----------------------------------|--|
| 1. Select the orientation. | - Specify landscape orientation (ESC i L) |
| 2. Specify the page size. | - Specify page length (ESC (C) |
| 3. Specify print area. | - Specify page format (ESC (c) - Specify left/right margins (ESC I, ESC Q) |
| 4. Specify the line feed amount. | - Specify line feed amount (ESC 0, ESC 2, ESC 3, ESC A) |
| 5. Specify tab positions. | - Specify horizontal tab position (ESC D) - Specify vertical tab position (ESC B) |



(3) Print operations

- | | |
|--|---|
| 1. Specify the print position. | - Specify the vertical position (ESC (v, ESC (V, VT, ESC J) - Specify the horizontal position (ESC \$, ESC \, HT, ESC a) |
| 2. Transfer the print data (one line). | - Transfer necessary text operation codes (see (4)), bit images, barcodes, and downloaded data (see (5)) |
| 3. End of the line. | - Feed the paper (CR, LF) |
| 4. Repeat 1–3 above. | |
| 5. End of the page. | - Specify cutting (ESC i C) - Feed the page (FF) |
| 6. Repeat 1–5 above. | |
| 7. End of the document. | |

(4) Text operations

- | | |
|---------------------------------|--|
| 1. Specify the character set. | <ul style="list-style-type: none"> - Select font (ESC k) - Select character code (ESC t) - Select international character set (ESC R) - Specify character size (ESC X) - Specify the character spacing (ESC P, ESC M, ESC SP) |
| 2. Specify the character style. | <ul style="list-style-type: none"> - Specify character style (ESC 4, ESC 5, ESC E, ESC F, ESC G, ESC H, ESC W, SO, ESC SO, SI, ESC SI, DC2, DC4, ESC -, ESC !) |
| 3. Specify character codes. | |
- Repeat 1–3 above as necessary.

(5) Bit images, barcodes, and image data

- | | |
|------------------------------|---|
| 1. Specify bit images. | - (ESC *, ESC K, ESC L, ESC Y, ESC Z) |
| 2. Specify barcodes. | - (ESC i B) |
| 3. Specify 2D barcodes. | - (ESC i Q, ESC i V, ESC i D, ESC i M, ESC i J) |
| 4. Print the downloaded data | <ul style="list-style-type: none"> - (ESC i F P) <p>An image data has to be transferred and registered to the printer first.</p> |

2. Examples of Using ESC/P Commands

Set Basic setup first.

Basic setup

- 1) Register a media to be used.
- 2) Specify ESC/P command mode.

Basic set up 1: Register a media to be used

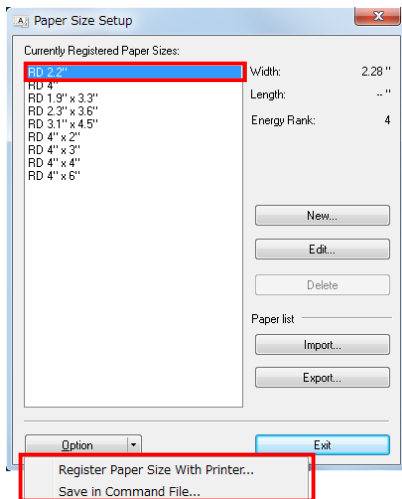

Register a media with the Custom Label tool.

Note: The media size to be used is also able to be output and saved as a command file with the Custom Label Tool.

Basic set up 2: Specify ESC/P command mode

ESC i a Switch command mode

| | | | | |
|--------------|-----|-----|----|---|
| ASCII: | ESC | i | a | n |
| Decimal: | 27 | 105 | 97 | n |
| Hexadecimal: | 1B | 69 | 61 | n |

Parameters

- n: Command mode
- 0 or 48: ESC/P standard mode**
 - 1 or 49: Raster graphics mode
 - 3 or 51: P-touch Template mode
 - 4 or 52: CPCL Page Print mode
 - 5 or 53 :CPCL Line Print mode

Entered Command

ESC i a 00h

Description

- Switches the command mode to ESC/P, P-touch Template, PTCBP (raster graphics) mode, CPCL Page Print mode and CPCL Line Print mode.
- Dynamically switches between the five modes.
- Since this is a dynamic command, after the printer is turned off and on again, the setting returns to the previously setting.

This is the label that will be made.

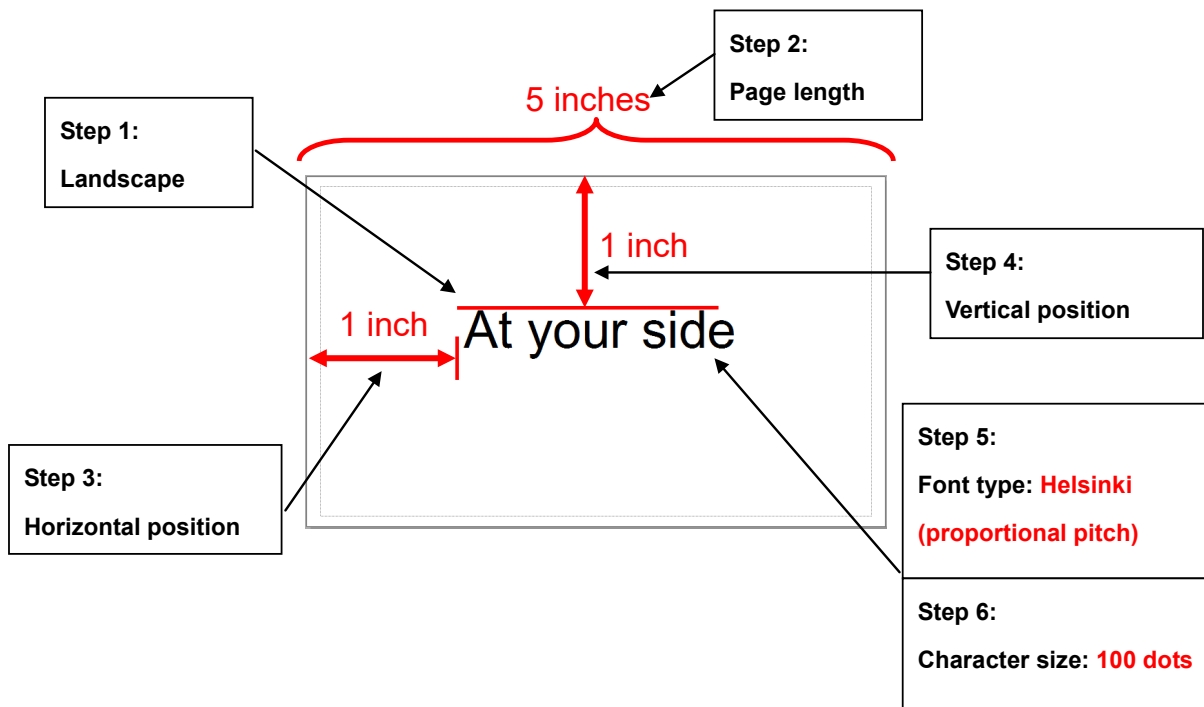

In order to make this label, the following six steps are required.

Step

1. Select the landscape orientation
2. Specify the page length
3. Specify the horizontal position
4. Specify the vertical position
5. Select the font type
6. Specify the character size

Step 1: Select the landscape orientation.

ESC i L Specify landscape orientation

| | | | | |
|--------------|-----|-----|----|---|
| ASCII: | ESC | i | L | n |
| Decimal: | 27 | 105 | 76 | n |
| Hexadecimal: | 1B | 69 | 4C | n |

Parameters

n=0, 1 or 48, 49

Description

- Applies or cancels the landscape orientation
 - n=1 or 49 ("1"): Applies the landscape orientation.
 - n=0 or 48 ("0"): Cancels the landscape orientation.
- Using this command clears all text.
- Before entering text, specify the paper orientation with this command.
- The setting specified by "ESC iXL2"(default landscape setting) is valid for the landscape orientation when the printer is turned on.

Entered command

ESC i L 01h

Step 2: Specify the page length.

ESC (C Specify page length

| | | | | | | | |
|--------------|-----|----|----|----|----|----|----|
| ASCII: | ESC | (| C | nL | nH | mL | mH |
| Decimal: | 27 | 40 | 67 | nL | nH | mL | mH |
| Hexadecimal: | 1B | 28 | 43 | nL | nH | mL | mH |



Parameters

- nL=2, nH=0
- 0 ≤ (mL+mH*256) < 8192 (for 203dpi printers)
- 0 ≤ (mL+mH*256) < 12000 (for 300dpi printers)

Description

- Specifies the page length.
- * A page length 0 indicates the Auto setting.
- The unit is 1 dot.
Page length=mL+mH*256
- The current paper position is the TOF.
- The top and bottom margins are canceled with ESC (c.
- All previously entered text is cleared.
- A standard unit is not used.
- This command is available only with continuous length tape.

5 inches=1015 dots

1015 dots - 48 dots = 967 dots

***The page length does not include the margins.**

For the margins, subtract 6 mm (48 dots) from the page length.

Page length=mL+mH*256=967

| | |
|-----|-----|
| | |
| 199 | 3 |
| | |
| C7h | 03h |

Entered command nL nH mL mH

ESC (C 02h 00h C7h 03h

Example: A case 203dpi printer is used

Step 3: Specify the horizontal position.

ESC \$ Specify absolute horizontal position

| | | | | |
|--------------|-----|----|----|----|
| ASCII: | ESC | \$ | n1 | n2 |
| Decimal: | 27 | 36 | n1 | n2 |
| Hexadecimal: | 1B | 24 | n1 | n2 |

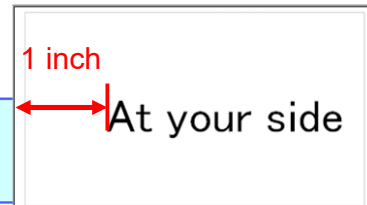

Parameters

- 0 ≤ n1 ≤ 255, 0 ≤ n2 ≤ 255

Description

- Specifies the absolute print position (in dots) for the next data.
- An absolute print position specifies the next print position as a number of dots from the left margin.
- n1 and n2 indicate the number of dots from the left margin.
(Number of dots=n1+n2*256)
- The dot spacing is calculated as 1/203 inch.
- The maximum number of dots that can be specified with n1 and n2 depends on the media.
- This command is available only with left alignment.

1 inch=203 dots

Horizontal position=n1+n2*256=203

| | |
|-----|-----|
| | |
| 203 | 0 |
| | |
| CBh | 00h |

Entered command n1 n2

ESC \$ CBh 00h

Example: A case 203dpi printer is used

Step 4: Specify the vertical position.

ESC (V Specify absolute vertical position

| | | | | | | | |
|--------------|-----|----|----|----|----|----|----|
| ASCII: | ESC | (| V | nL | nH | mL | mH |
| Decimal: | 27 | 40 | 86 | nL | nH | mL | mH |
| Hexadecimal: | 1B | 28 | 56 | nL | nH | mL | mH |

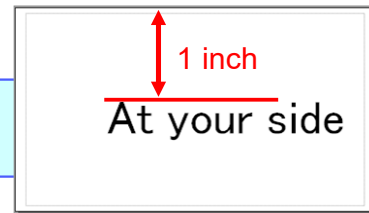

Parameters

- nL=2
- nH=0
- 0≤mL≤255
- 0≤mH≤127

Description

- Specifies the vertical print position as an absolute position from the top margin position.
- Vertical position=mL+mH*256+top margin**
- The absolute vertical position is measured from the top margin position when this command was specified.
- If a position extending beyond the bottom margin is specified, printing starts.
- There is no restriction on the amount of movement back (upward) from the current position.
- With left alignment, the print position for the next line becomes the end position of the current line. (The horizontal position does not move to the left margin.)
- With right alignment and center alignment, the horizontal position moves to the beginning of the line.
- Auto-canceling double-width characters specified with SO or ESC SO are canceled.

1 inch=203 dots

Vertical position=mL+mH*256=203

| | |
|-----|-----|
| | |
| 109 | 0 |
| | |
| CBh | 00h |

Entered command nL nH mL mH

| |
|-------------------------|
| ESC (V 02h 00h CBh 00h |
|-------------------------|

Example: A case 203dpi printer is used

Step 5: Select the font type.

ESC k Select font

| | | | |
|--------------|-----|-----|---|
| ASCII: | ESC | k | n |
| Decimal: | 27 | 107 | n |
| Hexadecimal: | 1B | 6B | n |

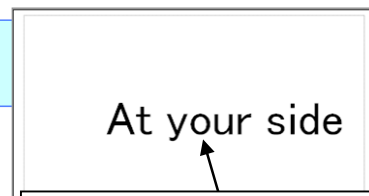

Parameters

- 0≤n≤4, 8≤n≤11

Description

- Selects the font.

| Bitmap Fonts | | Outline Fonts | |
|--------------|----------------------------------|---------------|-------------------------------|
| n=0 | Gothic (proportional pitch) | n=8 | Gothic (proportional pitch) |
| n=1 | Letter Gothic Bold (fixed pitch) | n=9 | Letter Gothic (fixed pitch) |
| n=2 | Reserved | n=10 | Brussels (proportional pitch) |
| n=3 | Helsinki (proportional pitch) | n=11 | Helsinki (proportional pitch) |
| n=4 | Reserved | | |

Font type: Helsinki
Outline Fonts

- The default value is n=1 (Letter Gothic Bold (fixed pitch)).
- If the font is changed from a bitmap font to outline font, the character size is changed to the default setting (28 dots).
- If the font is changed from an outline font to bitmap font, the character size is changed to default setting (24 dots).
- Proportional pitched Gothic is forced to be selected when a character assigned from 0x80 to 0xFF in the Japanese character code table is used.

n=11=0Bh

Entered command n

| |
|-----------|
| ESC k 0Bh |
|-----------|

Step 6: Specify the character size.

ESC X Specify character size

| | | | | | |
|--------------|-----|----|---|----|----|
| ASCII: | ESC | X | m | nL | nH |
| Decimal: | 27 | 88 | m | nL | nH |
| Hexadecimal: | 1B | 58 | m | nL | nH |

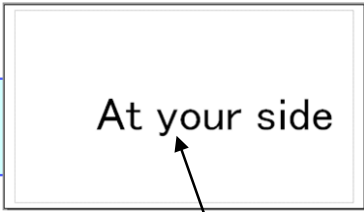

Parameters

| | | |
|------------------|--|--|
| Character width: | The value of m is irrelevant. | |
| Character size: | <Bitmap fonts> Valid only with: nL=16, 24, 32 dots nH=0 | <Outline fonts> The maximum is: nL=144 nH=1 |

Character size: 100 dots

Description

- This command is used only to change the size.
- Outline must not be specified.
- The character width cannot be specified.
- **The character size is specified as $n=nL+nH \uparrow 256$ dots.**
- The width and the height are the same.
- With bitmap fonts, only n=16, 24 and 32 are valid.
- With outline fonts, n=400 is the maximum.
- The commands for specifying stretched characters, compressed characters and the character spacing (SO, ESC W, ESC I, ESC SP) remain available.

Character size = $nL+nH \times 256 = 100$ dots

| | |
|------------|------------|
| | |
| 100 | 0 |
| | |
| 64h | 00h |

Entered command m nL nH

| | | | |
|-------|-----|-----|-----|
| ESC X | 00h | 64h | 00h |
|-------|-----|-----|-----|

Example: A case 203dpi printer is used

All commands together will make the example label shown below.

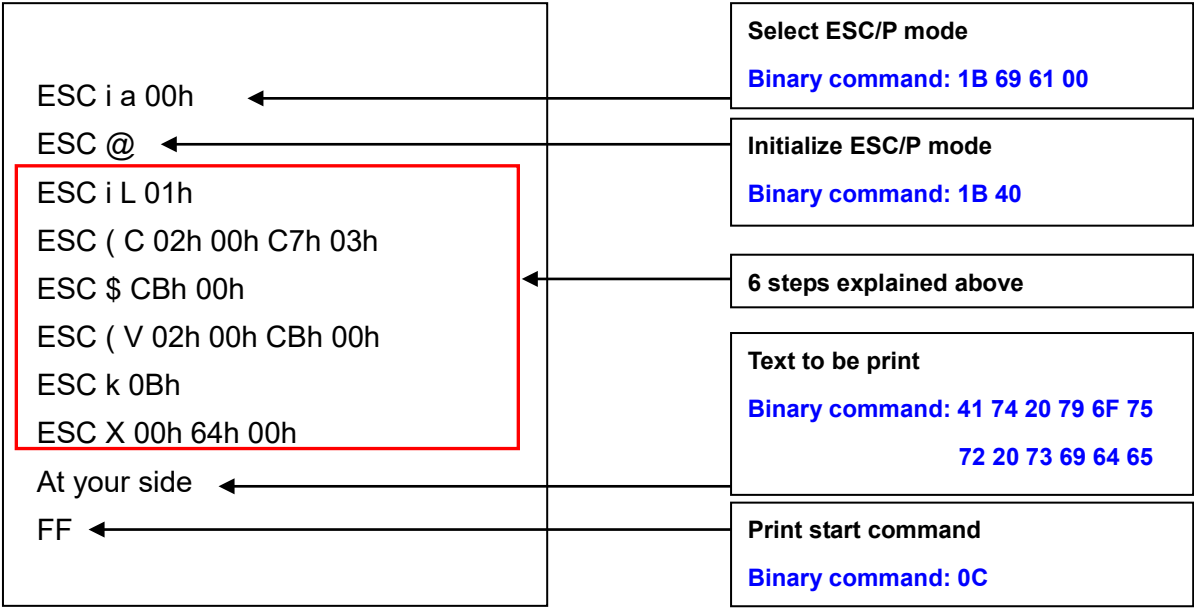

However, these commands should be converted to binary data before sent to the printer, as shown below. Here is the captured converted binary data.

```

1B 69 61 00 1B 40 1B 69 4C 01 1B 28 43 02 00 C7
03 1B 24 CB 00 1B 28 56 02 00 CB 00 1B 6B 0B 1B
58 00 64 00 41 74 20 79 6F 75 72 20 73 69 64 65
0C

```

When the printer receives above binary commands, the label shown below is printed.

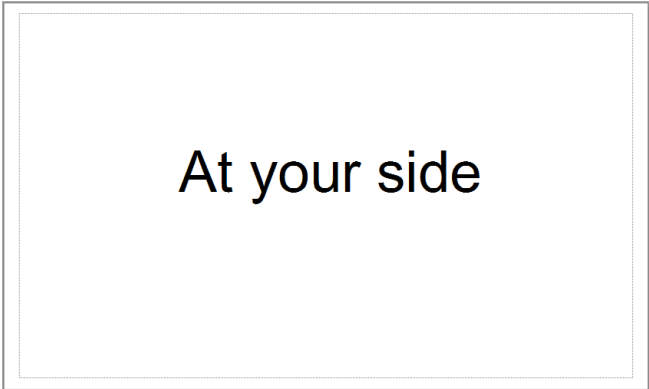

3. ESC/P Command Limitations

3.1 Print area

The printing media are continuous, die-cut labels and media with marks.

The area that can physically be printed on depends on the paper settings.

Die-cut labels

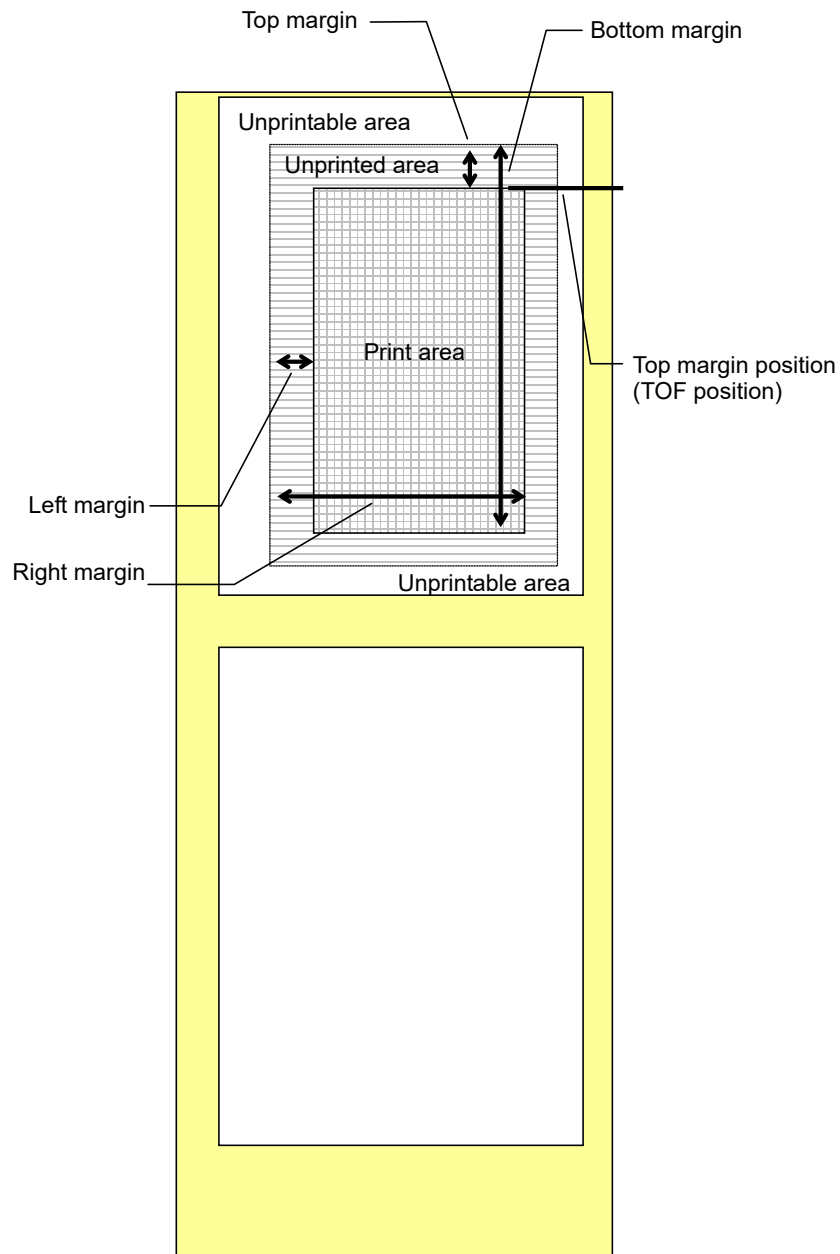

Print area

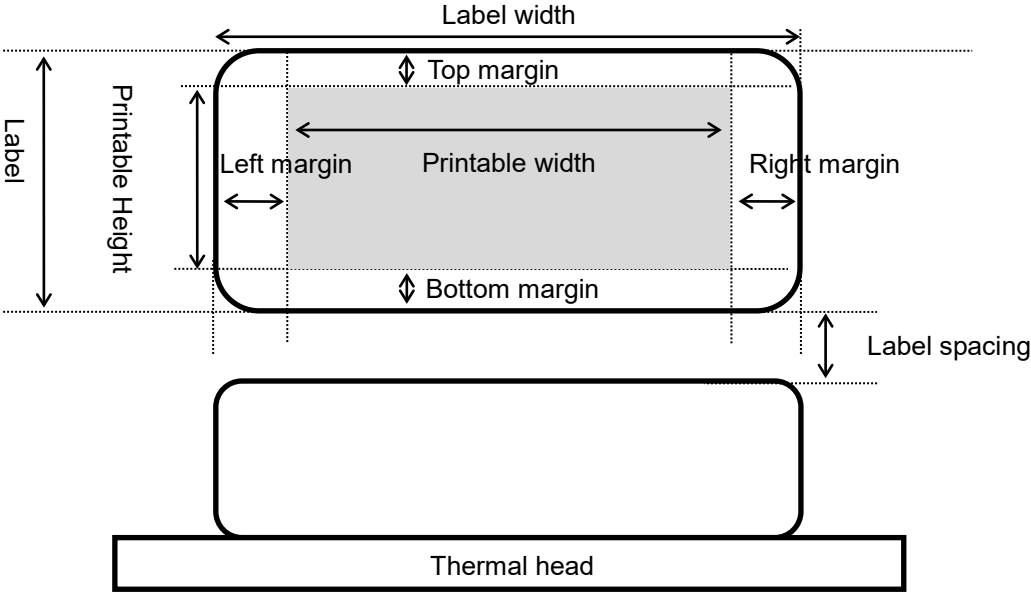

* To specify media settings, use the Custom Label Tool.

Note: The maximum length of printable area is 3m when a continuous label is used.

3.2 Characters

This system uses single-byte character codes and is installed with 6 bitmap fonts (Letter Gothic Bold, Helsinki, Gothic, Brussels, San Diego and Brougham) and 4 outline fonts (Letter Gothic, Brussels, Helsinki and Gothic).

Fixed pitch or proportional pitch can be specified for any of the fonts.

However, there are fonts that are better with a fixed pitch and fonts that are better with a proportional pitch.

The fonts that are better with a fixed pitch are: Letter Gothic and Letter Gothic Bold Brougham.

The font that is better with a proportional pitch are: Brussels, Helsinki and Gothic San Diego.

Each bitmap font has three sizes or four sizes: 16 dots, 24 dots, 32 dots and 48 dots.

Please refer to section [Appendix B: Specifications](#).

3.2.1 Character sizes

Each font is available in full size, compressed size (half width), double width, double height and half width, double height, and quadruple size.

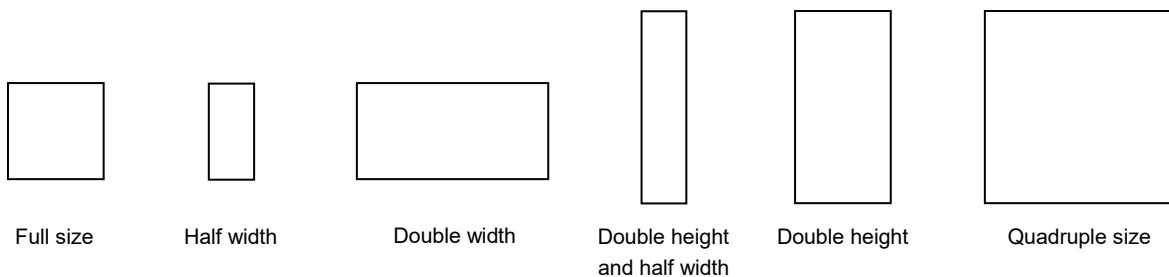

The actual character size is slightly smaller than the nominal size (the parameter value received with the size command). This varies depending on the font.

| | | | | |
|----------------|----|----|----|----|
| Nominal (dots) | 16 | 24 | 32 | 48 |
| Height (dots) | 15 | 21 | 28 | 44 |
| Width (dots) | 8 | 10 | 14 | 44 |

The above example is for Letter Gothic Bold (full size, no character styles applied).

The line-drawing characters (┌ ┐ ┆ ┇ ┈ ┉ ┊ ┋, etc.) and shaded characters have their own pitch regardless of the specified font and pitch (proportional or fixed) settings.

3.2.2 Character pitches

Pitch refers to the spacing between neighboring characters.

When characters are arranged with a fixed pitch, they will be evenly spaced.

If characters extend over several lines, they will align in straight rows.



When characters are arranged with a proportional pitch, the spacing will vary depending on the character. (For example, “W” is wide but “I” is narrow.)

As a result, the excess space between characters is eliminated and the text appears more compact.



If a fixed pitch is applied to a font that is better with a proportional pitch, all characters are given the same width as the widest character in the font.

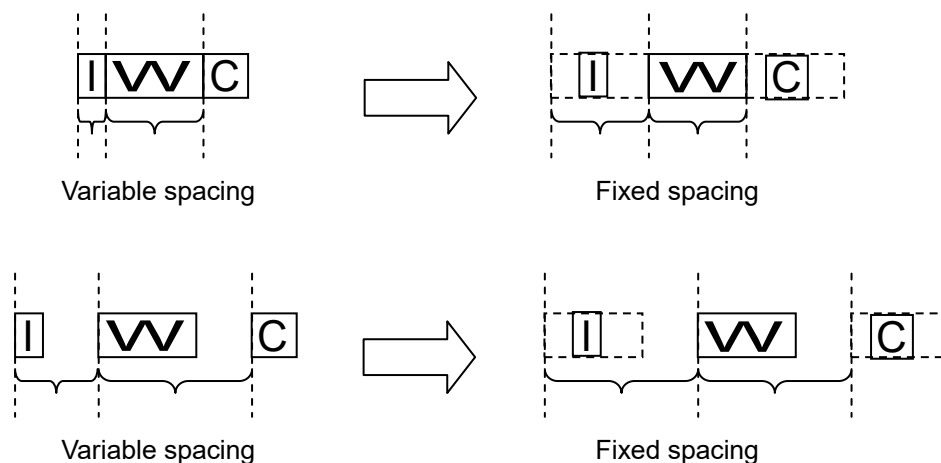

This makes it possible to evenly space the characters of a proportional-pitch font without having to change the font.

If a proportional pitch is applied to a font that is better with a fixed pitch, all characters are given the same width, appearing the same as with a fixed pitch.

3.3 Print position

The print position is the standard position for printing characters, bitmaps, and barcodes.

There is a horizontal print position and vertical print position, which are the reference points for vertical position movement and horizontal position movement.

3.3.1 Characters

Characters are arranged with their top edges aligned with the print position.

The baseline of each character is the bottom edge of the character, regardless of size, font, etc.

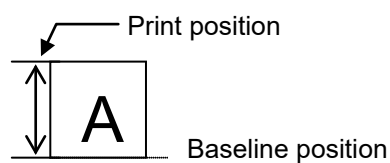

All characters on a single line are printed with a baseline positions that is the same for each character.

If a single line consists of characters with different heights, the characters are aligned with the baseline of the tallest character on the line.

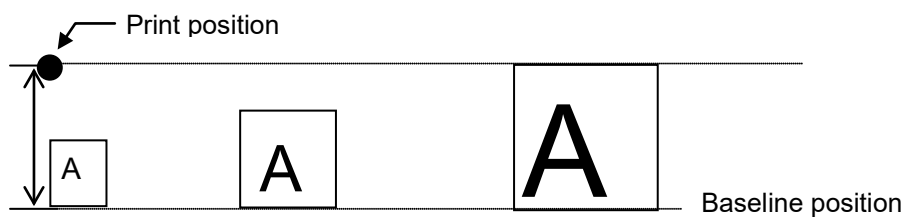

Underlines are drawn 4 dots below the baseline position.

3.3.2 Bitmaps, barcodes and downloaded images

These types of image data are treated in the same way as characters and are printed with the bottom edge of the image aligned with the baseline.

3.4 Line feed amount

The amount of line feed is the amount of vertical movement from the print position of one line to the print position of the next line.

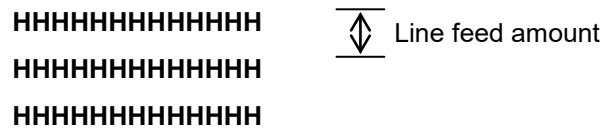

The line feed amount is specified with ESC 0, ESC 2, ESC A, and ESC 3.

- Within a single line of text, the tallest character is determined, and the baseline is moved so that the top edge of that character is at the vertical print position.
- The tallest character within a line becomes the line height.
- If characters are underlined, 4 dots are added to the line height.
- If the line height is greater than the specified line feed amount, the line height is used as the actual line feed amount.

In this way, even if the specified line feed amount is small, the upper and lower lines will not overlap.

(For printer-resident fonts.)

4. Control Code List

Character/style selection commands (Refer to section [5.1 Character/style selection commands.](#))

| Commands | Description | Note |
|----------|------------------------------------|------|
| ESC R | Select international character set | |
| ESC q | Select character style | |
| ESC k | Select font | |
| ESC t | Select character code set | |

Text printing commands (Refer to section [5.2 Text printing commands.](#))

| Commands | Description | Note |
|----------|---|------|
| ESC 4 | Apply italic style | |
| ESC 5 | Cancel italic style | |
| ESC E | Apply bold style | |
| ESC F | Cancel bold style | |
| ESC G | Apply double-strike printing | |
| ESC H | Cancel double-strike printing | |
| ESC P | Apply pica pitch (10 cpi) | |
| ESC M | Apply elite pitch (12 cpi) | |
| ESC q | Apply micron pitch (15 cpi) | |
| ESC p | Specify proportional characters | |
| ESC W | Specify double-width characters | |
| SO | Specify auto-canceling stretched characters | |
| ESC SO | Specify auto-canceling stretched characters | |
| SI | Specify compressed characters | |
| ESC SI | Specify compressed characters | |
| DC2 | Cancel compressed characters | |
| DC4 | Cancel auto-canceling double-width characters | |
| ESC - | Apply/cancel underlining | |
| ESC ! | Global formatting | |
| ESC SP | Specify character spacing | |
| ESC X | Specify character size | |

Line feed commands (Refer to section [5.3 Line feed commands.](#))

| Commands | Description | Note |
|----------|--------------------------------|------|
| ESC 0 | Specify line feed of 1/8 inch | |
| ESC 2 | Specify line feed of 1/6 inch | |
| ESC 3 | Specify minimum line feed | |
| ESC A | Specify line feed of n/60 inch | |

Horizontal movement commands (Refer to section [5.4 Horizontal movement commands.](#))

| Commands | Description | Note |
|----------|--------------------------------------|------|
| ESC I | Specify left margin | |
| ESC Q | Specify right margin | |
| CR | Carriage return | |
| ESC D | Specify horizontal tab position | |
| HT | Perform horizontal tab | |
| ESC \$ | Specify absolute horizontal position | |
| ESC \ | Specify relative horizontal position | |
| ESC a | Specify alignment | |

Vertical movement commands (Refer to section [5.5 Vertical movement commands.](#))

| Commands | Description | Note |
|----------|------------------------------------|------|
| LF | Line feed | |
| FF | Page feed | |
| ESC J | Forward paper feed | |
| ESC B | Specify vertical tab position | |
| VT | Perform vertical tab | |
| ESC (V | Specify absolute vertical position | |
| ESC (v | Specify relative vertical position | |

Paper formatting commands (Refer to section [5.6 Paper formatting commands.](#))

| Commands | Description | Note |
|----------|---------------------|------|
| ESC (c | Specify page format | |
| ESC (C | Specify page length | |

Printer control commands (Refer to section [5.7 Printer control commands.](#))

| Commands | Description | Note |
|----------|-----------------------|------|
| ESC @ | Initialize (defaults) | |
| ESC iUx | Reboot | |

Graphics commands (Refer to section [5.8 Graphics commands.](#))

| Commands | Description | Note |
|----------|---|------|
| ESC * | Select bit image. | |
| ESC K | 8-dot single-density bit image | |
| ESC L | 8-dot double-density bit image | |
| ESC Y | 8-dot double-speed double-density bit image | |
| ESC Z | 8-dot quadruple-density bit image | |

Advanced commands (Refer to section [5.9 Advanced commands.](#))

| Commands | Description | Note |
|-----------|-------------------------------|--------------------------------|
| ESC i B | Barcode | |
| ESC i Q | 2D barcode (QR Code) | |
| ESC i P | Specify QR Code version | |
| ESC i V | 2D barcode (PDF417) | |
| ESC i D | 2D barcode (DataMatrix) | |
| ESC i M | 2D barcode (MaxiCode) | |
| ESC i J | 2D barcode (Aztec) | |
| ESC i G | Specify font setting | |
| ESC i F P | Print downloaded data | |
| ESC i a | Switch command mode | |
| ESC i S | Status information request | |
| ESC i L | Specify landscape orientation | |
| ESC i C | Specify cutting | Only TD-4XXX printer supports. |
| ESC i H | Specify recovery setting | |

Advanced static commands (Refer to section [5.10 Advanced static commands.](#))

| Commands | Description | Note |
|-----------------|--|-------------------------------|
| ESC iXQ2 | Select default character style | |
| ESC iXQ1 | Retrieve default character style | |
| ESC iXk2 | Select default font | |
| ESC iXk1 | Retrieve default font | |
| ESC iXX2 | Specify default character size | |
| ESC iXX1 | Retrieve default character size | |
| ESC iX32 | Specify default line feed | |
| ESC iX31 | Retrieve default line feed | |
| ESC iXA2 | Select default alignment | |
| ESC iXA1 | Retrieve default alignment | |
| ESC iX(2 | Specify default page length | |
| ESC iX(1 | Retrieve default page length | |
| ESC iXL2 | Select default landscape orientation | |
| ESC iXL1 | Retrieve default landscape orientation | |
| ESC iXj2 | Select default international character set | |
| ESC iXj1 | Retrieve default international character set | |
| ESC iXm2 | Select default character code set | |
| ESC iXm1 | Retrieve default character code set | |
| ESC iXd2 | Specify recovery setting | |
| ESC iXd1 | Retrieve recovery setting | |
| ESC iXE2 | Specify barcode margin setting | |
| ESC iXE1 | Retrieve barcode margin setting | |
| ESC iX_2 (00h) | Specify line-print mode | |
| ESC iX_1(00h) | Retrieve line-print mode | |
| ESC iX_2 (01h) | Specify line-print timeout | |
| ESC iX_1 (01h) | Retrieve line-print timeout | |
| ESC iDC1SQ(01h) | Specify self-printing QR code content | Only RJ-3XXX printer supports |
| ESC iDC1SQ(00h) | Retrieve self-printing QR code content | Only RJ-3XXX printer supports |
| ESC iDC1SR(01h) | Select setting change lock | Only RJ-3XXX printer supports |
| ESC iDC1SR(00h) | Retrieve setting change lock | Only RJ-3XXX printer supports |

5. Control Command Details

5.1 Character/style selection commands

ESC R Select international character set

| | | | |
|--------------|-----|----|---|
| ASCII: | ESC | R | n |
| Hexadecimal: | 1B | 52 | n |

Parameters

$0 \leq n \leq 13, 64$

Description

- Selects the character set, and switches some of the character codes in the code table according to the value of n.
 - n=0: U.S.A.
 - n=1: France
 - n=2: Germany
 - n=3: U.K.
 - n=4: Denmark I
 - n=5: Sweden
 - n=6: Italy
 - n=7: Spain I
 - n=8: Japan
 - n=9: Norway
 - n=10: Denmark II
 - n=11: Spain II
 - n=12: Latin America
 - n=13: South Korea
 - n=64: Legal
- The following 12 codes are switched.
 - 23h, 24h, 40h, 5Bh, 5Ch, 5Dh, 5Eh, 60h, 7Bh, 7Ch, 7Dh, 7Eh
- The default setting is n=0 (U.S.A.)

Example

| | |
|---------------|----------------------|
| Code: | 5Ch ESC R 08h 5Ch FF |
| Print result: | \ ¥ |

ESC q Select character style

| | | | |
|--------------|-----|----|---|
| ASCII: | ESC | q | n |
| Hexadecimal: | 1B | 71 | n |

Parameters $0 \leq n \leq 3$ **Description**

- Selects the character style.
 - n=0: None (normal characters)
 - n=1: Outline
 - n=2: Shadow
 - n=3: Shadow and outline

Example

| | |
|---------------|------------------------------------|
| Code: | ABC ESC q 02h ABC ESC q 00h ABC FF |
| Print result: | ABC ABC ABC |

ESC k Select font

| | | | |
|--------------|-----|----|---|
| ASCII: | ESC | k | n |
| Hexadecimal: | 1B | 6B | n |

Parameters
 $0 \leq n \leq 5, 8 \leq n \leq 11$
Description

- Selects the font.

| Bitmap Fonts | | Outline Fonts | |
|--------------|----------------------------------|---------------|-------------------------------|
| n=0 | Gothic (proportional pitch) | n=8 | Gothic (proportional pitch) |
| n=1 | Letter Gothic Bold (fixed pitch) | n=9 | Letter Gothic (fixed pitch) |
| n=2 | Brussels (proportional pitch) | n=10 | Brussels (proportional pitch) |
| n=3 | Helsinki (proportional pitch) | n=11 | Helsinki (proportional pitch) |
| n=4 | San Diego (proportional pitch) | | |
| n=5 | Brougham (fixed pitch) | | |

- If the font is changed from a bitmap font to outline font, the character size is changed to the default setting (28 dots).
- If the font is changed from an outline font to bitmap font, the character size is changed to default setting (24 dots).
- If the selected font is not supported current size setting, character size is changed to the default setting (24 dots).
- Proportional pitched Gothic is forced to be selected when a character assigned from 0x80 to 0xFF in the Japanese character code table is used. If the character size is set to 48dot, it is not printed.
- The state at power-on is according to the setting of ESC iXk 2 (default type setting).
- Please refer to [Appendix B: Specifications](#) for model-specific information.

Font sample

1:Letter Gothic Bold(Bitmap)

0123456789

abcdefghijklmnopqrstuvwxyz

ABCDEFGHIJKLMNOPQRSTUVWXYZ

2:Brussels(Bitmap)

0123456789

abcdefghijklmnopqrstuvwxyz

ABCDEFGHIJKLMNOPQRSTUVWXYZ

3:Helsinki(Bitmap)

0123456789

abcdefghijklmnopqrstuvwxyz

ABCDEFGHIJKLMNOPQRSTUVWXYZ

4:San Diego(Bitmap)**0123456789****abcdefghijklmnopqrstuvwxyz****ABCDEFGHIJKLMNOPQRSTUVWXYZ**

5:Brougham (Bitmap)

0123456789

abcdefghijklmnopqrstuvwxyz

ABCDEFGHIJKLMNOPQRSTUVWXYZ

0:Gothic(Bitmap/Japanese)

。「」、・ヲアイウエオヤヨツーアイウエオカキクケコ
サシスセソチツテトナニヌネノハヒフヘホマミムメモヤヨラリルレロフン°

9:Letter Gothic(Outline)

0123456789

abcdefghijklmnopqrstuvwxyz

ABCDEFGHIJKLMNOPQRSTUVWXYZ

10:Brussels(Outline)

0123456789

abcdefghijklmnopqrstuvwxyz

ABCDEFGHIJKLMNOPQRSTUVWXYZ

11:Helsinki(Outline)

0123456789

abcdefghijklmnopqrstuvwxyz

ABCDEFGHIJKLMNOPQRSTUVWXYZ

8:Gothic(Outline/Japanese)

。「」、・ヲアイウエオヤヨツーアイウエオカキクケコ
サシスセソチツテトナニヌネノハヒフヘホマミムメモヤヨラリルレロフン°

ESC t Select character code set

| | | | |
|--------------|-----|----|---|
| ASCII: | ESC | t | n |
| Hexadecimal: | 1B | 74 | n |

Parameters $0 \leq n \leq 4$ **Description**

- From the four built-in character code sets, selects the character code set used.
 - n=0: Standard character code set
 - n=1: Eastern European character code set
 - n=2: Western European character code set
 - n=3: Reserved
 - n=4: Japanese character code set
- The default setting is n=0.
- Invalid if n is a value outside of the allowable range.

5.2 Text printing commands

ESC 4 Apply italic style

| | | |
|--------------|-----|----|
| ASCII: | ESC | 4 |
| Hexadecimal: | 1B | 34 |

Parameters

None

Description

- Prints the subsequent text in italics.
- This command is valid anywhere in a text line.

ESC 5 Cancel italic style

| | | |
|--------------|-----|----|
| ASCII: | ESC | 5 |
| Hexadecimal: | 1B | 35 |

Parameters

None

Description

- Cancels the italic character style.
- This command is valid anywhere in a text line.

Example

| | |
|---------------|----------------------------|
| Code: | ABC ESC 4 DEF ESC 5 GHI FF |
| Print result: | <i>ABCDEFGHI</i> |

ESC E Apply bold style

| | | |
|--------------|-----|----|
| ASCII: | ESC | E |
| Hexadecimal: | 1B | 45 |

Parameters

None

Description

- Prints the subsequent text in bold.
- This command is valid anywhere in a text line.

ESC F Cancel bold style

| | | |
|--------------|-----|----|
| ASCII: | ESC | F |
| Hexadecimal: | 1B | 46 |

Parameters

None

Description

- Cancels the bold style.
- This command is valid anywhere in a text line.

Example

| | |
|---------------|----------------------------|
| Code: | ABC ESC E DEF ESC F GHI FF |
| Print result: | ABC DEF GHI |

ESC G Apply double-strike printing

| | | |
|--------------|-----|----|
| ASCII: | ESC | G |
| Hexadecimal: | 1B | 47 |

Parameters

None

Description

- Prints the subsequent text in bold.
- This command is valid anywhere in a text line.

ESC H Cancel double-strike printing

| | | |
|--------------|-----|----|
| ASCII: | ESC | H |
| Hexadecimal: | 1B | 48 |

Parameters

None

Description

- Cancels the bold style.
- This command is valid anywhere in a text line.

Example

| | |
|---------------|----------------------------|
| Code: | ABC ESC G DEF ESC H GHI FF |
| Print result: | ABC DE FGHI |

ESC P Apply pica pitch (10 cpi)

| | | |
|--------------|-----|----|
| ASCII: | ESC | P |
| Hexadecimal: | 1B | 50 |

Parameters

None

Description

- Prints the subsequent text with the pica pitch (10 characters/inch).
- The character spacing is 20 dots (30 dots for 300dpi printers).
- If the character width is 20(or 30) dots or less, the character spacing is specified as 20(or 30) minus the character width.
- If the character width exceeds 20(or 30) dots, the character spacing is specified as the character width.
(The spacing between characters is 0 dot.)
In this case, the pitch does not exactly equal the pica pitch.
- With double-width characters, the character spacing is doubled (40(or 60) dots).
- With half-width characters, the character spacing is halved (10(or 15) dots).
- When the character spacing is changed with ESC SP, the setting is updated.
- This command is invalid when proportional pitch is selected.
- In outline fonts, the spacing between characters is 0 dot.
- Please refer to [Appendix B: Specifications](#).

| ● Setting (dots) | | Full Width | | | | Double Width | | | | Half Width | | | |
|---------------------|--------------------------|------------|----|----|----|--------------|----|----|-----|------------|----|----|----|
| | | 16 | 24 | 32 | 48 | 16 | 24 | 32 | 48 | 16 | 24 | 32 | 48 |
| Width (dots) | Gothic | 16 | 24 | 32 | - | 32 | 48 | 64 | - | 8 | 12 | 16 | - |
| | Letter Gothic Bold | 8 | 10 | 14 | 22 | 16 | 20 | 28 | 44 | 4 | 5 | 7 | 11 |
| | Brussels | - | 25 | 35 | 56 | - | 50 | 70 | 112 | - | 13 | 18 | 26 |
| | Helsinki | 16 | 21 | 28 | 44 | 30 | 42 | 56 | 88 | 8 | 11 | 14 | 22 |
| | San Diego | - | 24 | 35 | 57 | - | 48 | 70 | 114 | - | 12 | 18 | 29 |
| | Brougham | - | 11 | 16 | 26 | - | 22 | 32 | 52 | - | 6 | 8 | 13 |

The above table refers to characters with a fixed pitch. (Applying styles may increase the size.)

Example

For a 15-dot font at full width:

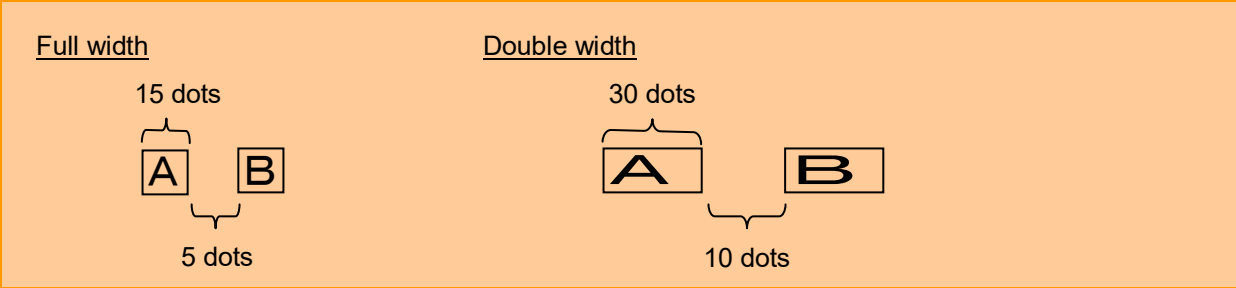

ESC M Apply elite pitch (12 cpi)

| | | |
|--------------|-----|----|
| ASCII: | ESC | M |
| Hexadecimal: | 1B | 4D |

Parameters

None

Description

- Prints the subsequent text with the elite pitch (12 characters/inch).
- The character spacing is 16 dots (25 dots for 300dpi printers).
- If the character width is 16(or 25) dots or less, the character spacing is specified as 16(or 25) minus the character width.
- If the character width exceeds 16(or 25) dots, the character spacing is specified as the character width.
(The spacing between characters is 0 dot.)

In this case, the pitch does not exactly equal the elite pitch.

- With double-width characters, the character spacing is doubled (32(or 50) dots).
- With half-width characters, the character spacing is halved (8(or 13) dots).
- When the character spacing is changed with ESC SP, the setting is updated.
- This command is invalid when proportional pitch is selected.
- In outline fonts, the spacing between characters is 0 dot.

Example

For a 15-dot font at full width:

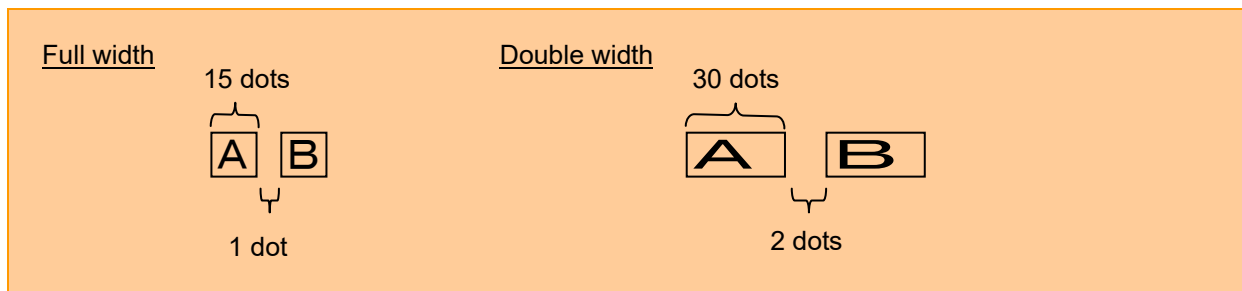

ESC g Apply micron pitch (15 cpi)

| | | |
|--------------|-----|----|
| ASCII: | ESC | g |
| Hexadecimal: | 1B | 67 |

Parameters

None

Description

- Prints the subsequent text with the micron pitch (15 characters/inch).
- This command is not applied to 203dpi printers.
- The character spacing is 20 dots.
- If the character width is 20 dots or less, the character spacing is specified as 20 minus the character width.
- If the character width exceeds 20 dots, the character spacing is specified as the character width.

(The spacing between characters is 0 dot.)

In this case, the pitch does not exactly equal the micron pitch.

- With double-width characters, the character spacing is doubled (40 dots).
- With half-width characters, the character spacing is halved (10 dots).
- When the character spacing is changed with ESC SP, the setting is updated.
- This command is invalid when proportional pitch is selected.
- In outline fonts, the spacing between characters is 0 dot.

Example

For a 11-dot font at full width:

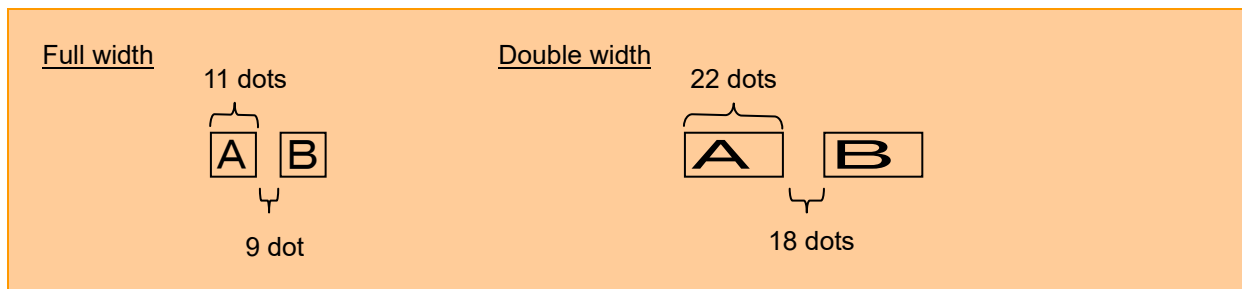

ESC p Specify proportional characters

| | | | |
|--------------|-----|----|---|
| ASCII: | ESC | p | n |
| Hexadecimal: | 1B | 70 | n |

Parameters

n=0, 1, 48 ("0"), 49 ("1")

Description

- Specifies proportional characters.
 - n=1 or 49 ("1"): Specifies proportional characters.
 - n=0 or 48 ("0"): Cancels proportional characters.
- If proportional characters are specified, the character spacing specified with ESC SP is maintained as is.

ESC W Specify double-width characters

| | | | |
|--------------|-----|----|---|
| ASCII: | ESC | W | n |
| Hexadecimal: | 1B | 57 | n |

Parameters

n=0, 1 or 48 ("0"), 49 ("1")

Description

- Specifies double-width characters.
 - n=1 or 49 ("1"): Specifies double-width characters.
 - n=0 or 48 ("0"): Cancels double-width characters.
- Double-width characters specified with this command are not canceled with the DC4 or a line feed.
- Canceling double-width characters also cancels compressed (half-width) characters.

Example

| | |
|---------------|--------------------------------|
| Code: | ABC ESC W 1 ABC ESC W 0 ABC FF |
| Print result: | ABC ABC ABC |

SO Specify auto-canceling stretched characters

| | |
|--------------|----|
| ASCII: | SO |
| Hexadecimal: | 0E |

Parameters

None

Description

- Prints the subsequent text at double width.
- This command is canceled with DC4, CR, LF, VT, FF, ESC J, or an automatic line feed.
- This command is canceled with ESC \$, ESC \, ESC (V or ESC (v.
- This command can also be canceled with ESC W0.

ESC SO Specify auto-canceling stretched characters

| | | |
|--------------|-----|----|
| ASCII: | ESC | SO |
| Hexadecimal: | 1B | 0E |

Parameters

None

Description

- Same as SO

Example

| | |
|---------------|---|
| Code: | ABC ESC SO ABCDEFGHIJK...XYZ FF |
| Print result: | ABC ABCDEFGHIJK . . . (Automatic line feed) XYZ |

SI Specify compressed characters

| | |
|--------------|----|
| ASCII: | SI |
| Hexadecimal: | 0F |

Parameters

None

Description

- Prints the subsequent text at half width.

ESC SI Specify compressed characters

| | | |
|--------------|-----|----|
| ASCII: | ESC | SI |
| Hexadecimal: | 1B | 0F |

Parameters

None

Description

- Same as SI

DC2 Cancel compressed characters

ASCII: DC2
Hexadecimal: 12

Parameters

None

Description

- Cancels compressed characters specified with SI.

DC4 Cancel auto-canceling double-width characters

ASCII: DC4
Hexadecimal: 14

Parameters

None

Description

- Cancels double-width characters specified with ESC SO or SO.
- Does not cancel the ESC W command.

Example

Code: ABC ESC SO ABCDEF DC4 GHIJK FF
Print result: ABC**ABCDEF**GHIJK

ESC – Apply/cancel underlining

| | | | |
|--------------|-----|----|---|
| ASCII: | ESC | - | n |
| Hexadecimal: | 1B | 2D | n |

Parameters

n=0, 1, 2, 3, 4 or 48 (“0”), 49 (“1”), 50 (“2”), 51 (“3”), 52 (“4”)

Description

- Applies or cancels underlining.
 - n=4 or 52 (“4”): Applies underlining with a width of 4 dots.
 - n=3 or 51 (“3”): Applies underlining with a width of 3 dots.
 - n=2 or 50 (“2”): Applies underlining with a width of 2 dots.
 - n=1 or 49 (“1”): Applies underlining with a width of 1 dot.
 - n=0 or 48 (“0”): Cancels underlining.
- This command is valid anywhere in a text line.
- The underlining specified with this command is a continuous line.
- Spaces between characters and words are also underlined.
- Areas with the “specify absolute horizontal position” (ESC \$) and “specify relative horizontal position” (ESC \) commands are not underlined.
- 4 dots is added to the line feed amount for lines that include underlined characters.
- The underline is positioned as follows:

| Underline | Underline Position |
|-------------|--|
| 1 dot wide | 2 dots below the characters |
| 2 dots wide | Between 2 dots and 3 dots below the characters |
| 3 dots wide | Between 1 dot and 3 dots below the characters |
| 4 dots wide | Between 1 dot and 4 dots below the characters |

ABCDE ABCDE ABCDE
 (1-dot width) (3-dot width)

Example

| | |
|---------------|--------------------------------|
| Code: | ABC ESC - 1 ABC ESC - 0 ABC FF |
| Print result: | ABC <u>ABC</u> ABC |

ESC ! Global formatting

| | | | |
|--------------|-----|----|---|
| ASCII: | ESC | ! | n |
| Hexadecimal: | 1B | 21 | n |

Parameters

0≤n≤255

Description

- Specifies a combination of print modes.
- Specifies modes depending on the bit value of n.
- When the ESC ! code is used, a combination of multiple print modes can be specified at one time.
- The priority order is from Bit 5 to Bit 2.
- Bit 0 is available only if Bit 1 is 0.
- Selected character styles are canceled, and the characters return to the normal style.
- Canceling double-width characters also cancels compressed (half-width) characters.

| Bit | 7 | 6 | 5 | 4 | 3 | 2 | 1 | 0 |
|-----|-----------|---------|--------------|---------------|--------|------------|--------------|--------|
| 1 | Underline | Italics | Double width | Double height | Bold | Compressed | Proportional | 12 cpi |
| 0 | Cancel | Cancel | Cancel | Cancel | Cancel | Cancel | Cancel | 10 cpi |

Example

- To apply underlining and specify double-width characters at the same time:

| | |
|---------------|------------------------------------|
| Code: | ABC ESC ! A2h ABC ESC ! 00h ABC FF |
| Print result: | ABC <u>ABCA</u> B C |

ESC SP Specify character spacing

| | | | |
|--------------|-----|----|---|
| ASCII: | ESC | SP | n |
| Hexadecimal: | 1B | 20 | n |

Parameters $0 \leq n \leq 127$ **Description**

- Specifies the character spacing.
- n indicates the number of dots.
- The default setting is 0 dot.
- With double-width characters, the character spacing is doubled; with half-width characters, it is halved.

ESC X Specify character size

| | | | | | |
|--------------|-----|----|---|----|----|
| ASCII: | ESC | X | m | nL | nH |
| Hexadecimal: | 1B | 58 | m | nL | nH |

Parameters

| | | |
|------------------|--|--|
| Character width: | The value of m is irrelevant. | |
| Character size: | <Bitmap fonts> Valid only with: nL=16, 24, 32, 48 dots nH=0 | <Outline fonts> The maximum is: nL=144 nH=1 |

Description

- This command is used only to change the size.
- Outline must not be specified.
- The character width cannot be specified.
- The character size is specified as $n=nL+nH*256$ dots.
- With bitmap font Gothic, only $n=16, 24$ and 32 are valid.
- With bitmap font Letter Gothic Bold and Helsinki, only $n=16, 24, 32$ and 48 are valid.
- With bitmap font Brussels, San Diego and Brougham, only $n=24, 32$ and 48 are valid.
- With outline fonts, $n=400$ is the maximum.
- The commands for specifying stretched characters, compressed characters and the character spacing (SO, ESC W, SI, ESC !, ESC SP) remain available.
- Please refer to [Appendix B: Specifications](#).

Example

For "ABC" at a 24-dot size and "DEF" at a 48-dot size:

| | |
|---------------|--------------------------|
| Code: | ESC k 01h |
| | ESC X 00h 18h 00h ABC |
| | ESC k 09h |
| | ESC X 00h 30h 00h DEF FF |
| Print result: | ABC DEF |

5.3 Line feed commands

ESC 0 Specify line feed of 1/8 inch

| | | |
|--------------|-----|----|
| ASCII: | ESC | 0 |
| Hexadecimal: | 1B | 30 |

Parameters

None

Description

- Specifies a line feed of 1/8 inch (about 0.32 cm).

ESC 2 Specify line feed of 1/6 inch

| | | |
|--------------|-----|----|
| ASCII: | ESC | 2 |
| Hexadecimal: | 1B | 32 |

Parameters

None

Description

- Specifies a line feed of 1/6 inch (about 0.42 cm).

ESC 3 Specify minimum line feed

| | | | |
|--------------|-----|----|---|
| ASCII: | ESC | 3 | n |
| Hexadecimal: | 1B | 33 | n |

Parameters $0 \leq n \leq 255$ Description

- Specifies a line feed of n dots per line.

ESC A Specify line feed of n/60 inch

| | | | |
|--------------|-----|----|---|
| ASCII: | ESC | A | n |
| Hexadecimal: | 1B | 41 | n |

Parameters $0 \leq n \leq 255$ Description

- Specifies a line feed of n/60 inch.

5.4 Horizontal movement commands

ESC I **Specify left margin**

| | | | |
|--------------|-----|----|---|
| ASCII: | ESC | I | n |
| Hexadecimal: | 1B | 6C | n |

Parameters

$0 \leq n \leq 255$

$0 \leq \text{left margin} < \text{right margin}$

Description

- The left margin and the right margin use the left edge of the physically printable area as the reference.
- The area between the left edge of the physically printable area and the specified number of columns is specified as an unprinted area. The left margin position is the right edge of the specified column. (Character width*n)
- The setting is in the range $0 \leq (\text{character width} * n) \leq x$. Settings outside that range are ignored. However, x is a value dependent on the media.
- The area between the left edge (first column) to the nth column is specified as an unprinted area.
- The position of the left margin is the character width (when this command was specified)*n from the left edge.

The character width when the margin specified includes the settings for the character spacing, full-width character spacing or half-width character spacing. In addition, when a pitch of 10 cpi, 12 cpi or 15 cpi, compressed characters or double-width characters are specified, that character width is considered as the unit.

However, character styles that increase the character width are not applied.

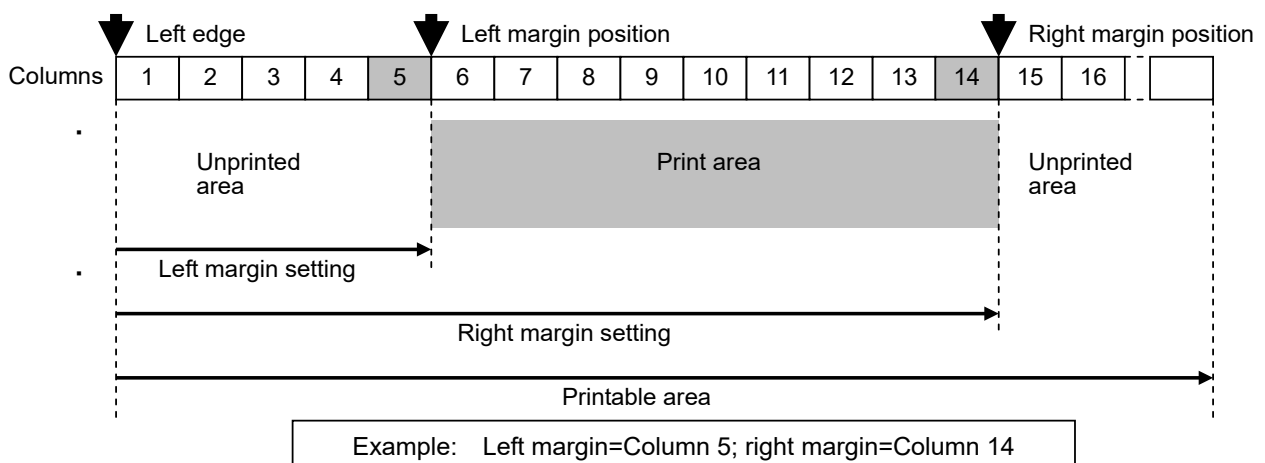

- The horizontal print position is moved to the left margin position.
- If the left margin setting is not at the beginning of the line, the left margin is specified after a line feed.
The beginning of the line indicates the left margin position for left alignment; for right and center alignment, it means that no image or character is entered on the line.
- Even if the character width is changed after the left margin has been specified, the left margin position does not change.
- A left margin setting that puts the left margin position to the right of the right margin position is ignored.
- The left margin should be specified at least one column less than the right margin.
- If the difference between the right margin position and the left margin position is less than one character, that character is ignored.
- When proportional pitch is specified with the ESC p command, a character width of 10 cpi is applied.
- If the print media is continuous length tape, the printing orientation is landscape and the page length is not specified, commands specifying the left margin are ignored.

Example

To specify the left margin at Column 3:

| | |
|---------------|-------------------------------|
| Code: | ABC CR ESC I 03h EFGHIJ FF |
| Print result: | <pre> ABC EFGHIJ </pre> |

ESC Q Specify right margin

| | | | |
|--------------|-----|----|---|
| ASCII: | ESC | Q | n |
| Hexadecimal: | 1B | 51 | n |

Parameters
 $1 \leq n \leq 255$
 $\text{Left margin} < \text{character width (when the command was specified)} * n \leq \text{printable area}$
Description

- The left margin and the right margin use the left edge of the physically printable area as the reference.
- The right margin position is the right edge of the specified column. (Character width*n)
- The setting is in the range $1 \leq (\text{character width} * n) \leq x$. Settings outside that range are ignored. However, x is a value dependent on the media.
- $\text{Left margin} \leq \text{print area} < \text{right margin}$
- The position of the right margin is the character width (when the command was specified)*n from the left edge.
The character width when the margin is specified includes the settings for the character spacing, full-width character spacing or half-width character spacing. In addition, when a pitch of 10 cpi ,12 cpi or 15cpi, compressed characters or double-width characters are specified, that character width is considered as the unit.
However, character styles that increase the character width are not applied.
- The horizontal print position is moved to the left margin position.
- If the right margin setting is not at the beginning of the line, the right margin is specified after a line feed.
The beginning of the line indicates the left margin position for left alignment; for right and center alignment, it means that no image or character is entered on the line.
- Even if the character width is changed after the right margin has been specified, the right margin position does not change.
- A right margin setting that puts the right margin position to the left of the left margin position is ignored.
- The right margin should be specified at least one column greater than the left margin.
- If the difference between the right margin position and the left margin position is less than one character, that character is ignored.
- When proportional pitch is specified with the ESC p command, a character width of 10 cpi is applied.
- If the print media is continuous length tape, the printing orientation is landscape and the page length is not specified, commands specifying the right margin are ignored.

CR Carriage return

| |
|-----------------|
| ASCII: CR |
| Hexadecimal: 0D |

Parameters

None

Description

- Ends input of a line, and waits for input of the next line.
- The next print position becomes the beginning of the next line.
- A line feed command immediately after the carriage return is ignored.
- Auto-canceling double-width characters specified with SO or ESC SO are canceled.
- Same process as LF

ESC D Specify horizontal tab position

| | | | | |
|--------------|-----|----|------------------|-----|
| ASCII: | ESC | D | [n] _k | NUL |
| Hexadecimal: | 1B | 44 | [n] _k | 00h |

Parameters
 $1 \leq n \leq 255, 0 \leq k \leq 32$
Description

- The horizontal tab position is the character width (when the command was specified)*n from the left margin.
 - Enter n values in ascending order and end the settings with NUL.
 - If an n value is smaller than a previous one, tab setting is ended.
 - Even if the character width is changed after the horizontal tab positions have been specified, the horizontal tab position settings do not change.
 - ESC D NUL cancels all horizontal tab positions.
 - If the left margin is moved, the horizontal tab positions are also moved by the same amount.
 - Up to 32 horizontal tab positions can be specified. However, horizontal tab positions beyond the right margin are invalid and only become valid when a change in the right margin setting or left margin setting moves the print area to include those tab positions.
 - The character width when the horizontal tabs are specified includes the settings for the character spacing, full-width character spacing or half-width character spacing. In addition, when a pitch of 10 cpi, 12 cpi, or 15 cpi, compressed characters or double-width characters are specified, that character width is considered as the unit.
 - When proportional pitch is specified with ESC p, horizontal tab positions are specified at 10 cpi.
 - When the printer is turned on, a horizontal tab position is specified every 8 columns at 10 cpi.
- Even if the character width is changed before the horizontal tab positions has been specified, the horizontal tab positions do not change.

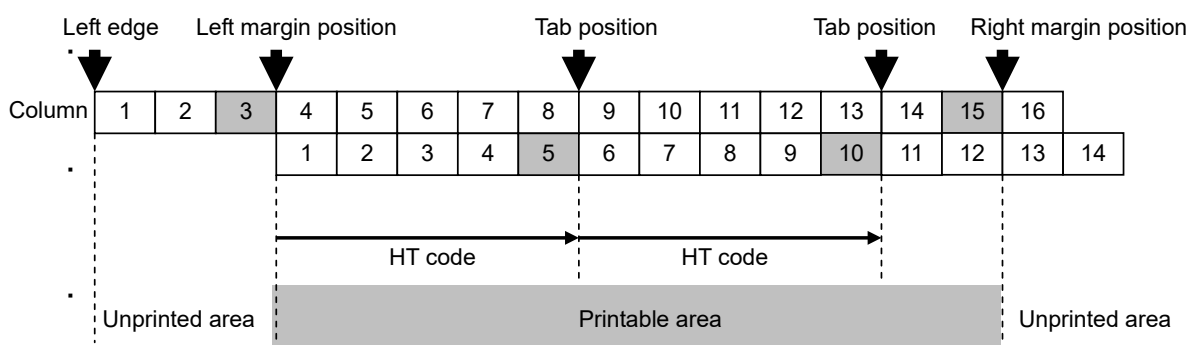
**Example:**

After the left margin is specified as Column 3 and the right margin as Column 15, horizontal tabs were specified at Column 5 and Column 10, and HT were performed.

HT Perform horizontal tab

| | |
|--------------|----|
| ASCII: | HT |
| Hexadecimal: | 09 |

Parameters

None

Description

- Moves the horizontal print position to the nearest horizontal tab position to the right of the input position.
- If there is no horizontal tab position to the right of the input position, or if the next horizontal tab position is beyond the right margin, the HT command is ignored.
- If underlining is specified, the space between the current position and the next horizontal tab position is not underlined.
- When the printer is turned on, a horizontal tab position is specified every 8 columns at 10 cpi. Even if the character width is changed before the horizontal tab positions have been specified, the horizontal tab positions do not change.
- This command is available only with left alignment.

Example

To specify horizontal tabs at Column 4, Column 8, and Column 12, and perform horizontal tabs:

| | |
|---------------|-------------------------------------|
| Code: | ESC D 04h 08h 0Ch 00h |
| | 123456789012 CR A HT B HT C HT D FF |
| Print result: | 123456789012 |
| | A B C D |

ESC \$ Specify absolute horizontal position

| | | | | |
|--------------|-----|----|----|----|
| ASCII: | ESC | \$ | n1 | n2 |
| Hexadecimal: | 1B | 24 | n1 | n2 |

Parameters
 $0 \leq n1 \leq 255, 0 \leq n2 \leq 255$
Description

- Specifies the absolute print position (in dots) for the next data.
- An absolute print position specifies the next print position as a number of dots from the left margin.
- n1 and n2 indicate the number of dots from the left margin.
(Number of dots= $n1+n2*256$)
- The maximum number of dots that can be specified with n1 and n2 depends on the media.
- This command is available only with left alignment.

ESC \ Specify relative horizontal position

| | | | | |
|--------------|-----|----|----|----|
| ASCII: | ESC | \ | n1 | n2 |
| Hexadecimal: | 1B | 5C | n1 | n2 |

Parameters
 $0 \leq n1 \leq 255, 0 \leq n2 \leq 255$
Description

- Specifies the horizontal print position (in dots) as a relative position from the current position.
- A relative position specifies the next print position as a number of dots from the current position.
- n1 and n2 indicate the number of dots from the current position. (Number of dots= $n1+n2*256$)
- Left margin position \leq horizontal position after moving $<$ right margin position
Horizontal position after moving= $n1+n2*256$
- The specified value for moving to the left is expressed as a two's complement. It is determined by the following equation.
 $n1+n2*256=65536$ -distance actually moved
- This command is available only with left alignment.

ESC a Specify alignment

| | | | |
|--------------|-----|----|---|
| ASCII: | ESC | a | n |
| Hexadecimal: | 1B | 61 | n |

Parameters

$0 \leq n \leq 3$ or "0" ≤ n ≤ "3"

Description

- Prints the subsequent text with the alignment described below, according to the value of n.
 - n=0 or 48 ("0"): Applies left alignment.
 - n=1 or 49 ("1"): Applies center alignment.
 - n=2 or 50 ("2"): Applies right alignment.
 - n=3 or 51 ("3"): Applies nothing.
- The default setting is n=0.
- Data is aligned between the left and right margins by entering a CR, LF, and FF code or by buffer printing.
- If the alignment setting is not at the beginning of the line, the alignment is specified after a line feed.
 - The beginning of the line indicates the left margin position for left alignment;
 - for right and center alignment, it means that no image or character is entered on the line.
- HT, ESC \ and ESC \$ are ignored when n=1 or n=2.
- If the print media is continuous length tape, the printing orientation is landscape and the page length is not specified, commands specifying alignment are ignored.

5.5 Vertical movement commands

LF **Line feed**

ASCII: LF
Hexadecimal: 0A

Parameters

None

Description

- Feeds the paper by the amount specified by a line feed command (ESC 0, ESC 2, ESC 3, ESC A).
- The print position becomes the beginning of the next line.
- The default value is a line feed of 32 dots.
- A carriage return immediately after a line feed is ignored.
- Auto-canceling double-width characters specified with SO or ESC SO are canceled.
- Same process as CR

FF **Page feed**

ASCII: FF
Hexadecimal: 0C

Parameters

None

Description

- Starts the printing.
- The previously entered data string of characters and commands is cleared after being printed.
- At this time, auto-canceling double-width characters specified with SO or ESC SO are canceled.

ESC J Forward paper feed

| | | | |
|--------------|-----|----|---|
| ASCII: | ESC | J | n |
| Hexadecimal: | 1B | 4A | n |

Parameters

0≤n≤255

Description

- Ends input for the current line and moves the vertical print position forward by n dot.
- If the bottom margin setting is exceeded, printing starts.
- With left alignment, the print position for the next line becomes the end position of the current line.
(The horizontal position does not move to the left margin.)
With right alignment and center alignment, the horizontal position moves to the beginning of the line.
- Auto-canceling double-width characters specified with SO or ESC SO are canceled.

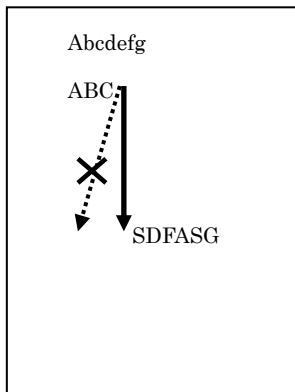
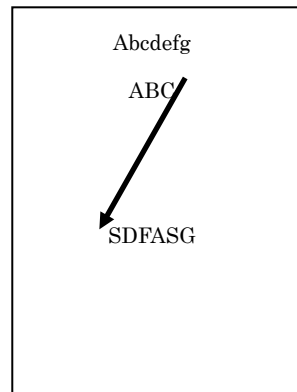
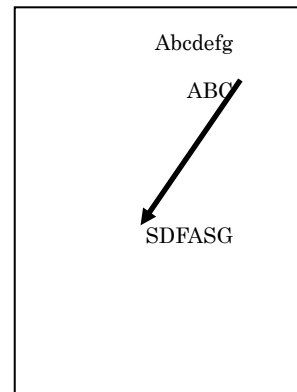
Left alignmentCenter alignmentRight alignment

| |
|--|
| Example: Performing a forward paper feed after the second line |
|--|

ESC B Specify vertical tab position

| | | | | |
|--------------|-----|----|------------------|-----|
| ASCII: | ESC | B | [n] _k | NUL |
| Hexadecimal: | 1B | 42 | [n] _k | 00h |

Parameters
 $1 \leq n \leq 255$
 $0 \leq k \leq 16$
Description

- The vertical tab position is the line feed amount (when this command was specified)*n from the top margin.
- Enter n values in ascending order and end the settings with NUL.
- If an n value is smaller than a previous one, tab setting is ended.
- Up to 16 vertical tabs can be specified.
- ESC B NUL cancels all vertical tab positions.
- Vertical tab positions can be specified regardless of the setting of the bottom margin position. However, vertical tab positions outside the print area (beyond the bottom margin position) are invalid and only become valid when a change in the top margin setting or bottom margin setting moves the print area to include those tab positions.
- Use VT to move to the vertical tab position.
- When changing vertical tab positions, specify all positions again.
- If the top margin is moved, the vertical tab positions are also moved by the same amount.
- Even if the line feed amount is changed after the vertical tab positions have been specified, the vertical tab position settings do not change.
- Performing a VT when no vertical tabs have been specified is equal to performing a CR.

VT Perform vertical tab

| | |
|--------------|----|
| ASCII: | VT |
| Hexadecimal: | 0B |

Parameters

None

Description

- Moves the print position to the nearest vertical tab position down from the input position.
- The next horizontal print position becomes the beginning of the line.
- If the next vertical tab position extends beyond the bottom margin, or if there is no vertical tab position specified below the current position, VT is performed as if it is (moves to the TOF position of the next page).

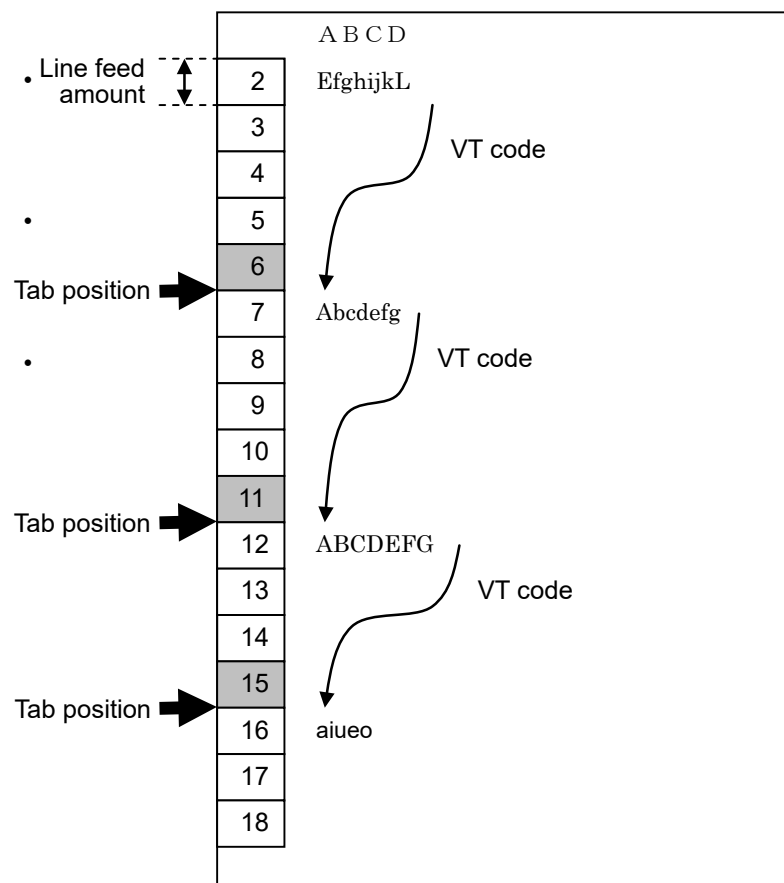

Example: Vertical tabs are specified at Lines 6, 11, and 15, and data is entered while VT are performed.

- When all vertical tab positions have been canceled by an initialization or with ESC B NUL, performing VT is equal to performing CR.
- Auto-canceling double-width characters specified with SO or ESC SO are canceled.

ESC (V) Specify absolute vertical position

| | | | | | | | |
|--------------|-----|----|----|----|----|----|----|
| ASCII: | ESC | (| V | nL | nH | mL | mH |
| Hexadecimal: | 1B | 28 | 56 | nL | nH | mL | mH |

Parameters

nL=2

nH=0

0≤mL≤255

0≤mH≤127

Description

- Specifies the vertical print position as an absolute position from the top margin position.
Vertical position=mL+mH*256+top margin
- The absolute vertical position is measured from the top margin position when this command was specified.
- If a position extending beyond the bottom margin is specified, printing starts.
- There is no restriction on the amount of movement back (upward) from the current position.
- With left alignment, the print position for the next line becomes the end position of the current line.
(The horizontal position does not move to the left margin.)
With right alignment and center alignment, the horizontal position moves to the beginning of the line.
- Auto-canceling double-width characters specified with SO or ESC SO are canceled.

ESC (v) Specify relative vertical position

| | | | | | | | |
|--------------|-----|----|----|----|----|----|----|
| ASCII: | ESC | (| v | nL | nH | mL | mH |
| Hexadecimal: | 1B | 28 | 76 | nL | nH | mL | mH |

Parameters

nL=2

nH=0

 $0 \leq mL \leq 255$ $0 \leq mH \leq 63, 192 \leq mH \leq 255$ $-16384 \leq (mL + mH * 256) \leq 16383$ Description

- Specifies the vertical position as a relative position from the current position.
Vertical position after movement = $mL + mH * 256 + \text{current position}$
- When moving upwards, the specified value is expressed as a two's complement.
It is determined by the following equation.
 $mL + mH * 256 = 65536 - \text{distance actually moved}$
- Settings moving the print position above the top margin are ignored.
- If a position extending beyond the bottom margin is specified, printing starts.
- With left alignment, the print position for the next line becomes the end position of the current line.
(The horizontal position does not move to the left margin.)
With right alignment and center alignment, the horizontal position moves to the beginning of the line.
- Auto-canceling double-width characters specified with SO or ESC SO are canceled.

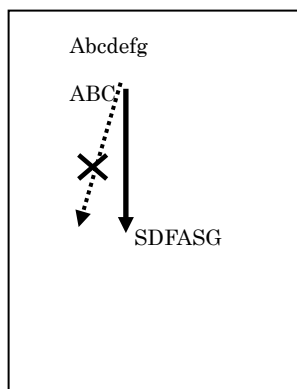
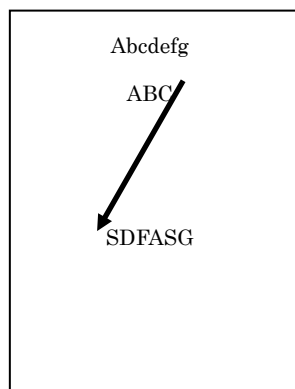
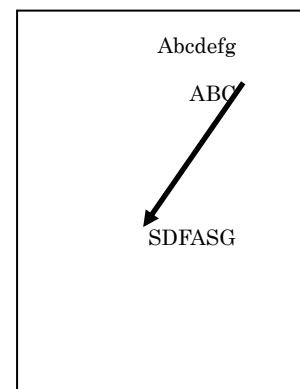
Left alignmentCenter alignmentRight alignment

Example: Moving to a vertical position specified after the second line

5.6 Paper formatting commands

ESC (c Specify page format

| | | | | | | | | | |
|--------------|-----|----|----|----|----|----|----|----|----|
| ASCII: | ESC | (| c | nL | nH | tL | tH | BL | BH |
| Hexadecimal: | 1B | 28 | 63 | nL | nH | tL | tH | BL | BH |

Parameters

nL=4, nH=0

$(tL+tH*256) < (BL+BH*256)$

Top margin < bottom margin

Description

- Specifies settings for the top and bottom margins.
- The physically printable area depends on the media.
The top margin and the bottom margin are specified in units of 1 dot using the top edge of the physically printable area as the reference.
(The left margin and the right margin use the left edge of the physically printable area as the reference.)
- Top margin = $tL+tH*256$
- Bottom margin = $BL+BH*256$
- The top margin position is the TOF in the vertical direction.
- All previously entered text is cleared.
- When this command is used previously specified top and bottom margins are canceled.
- A standard unit is not used.
- If the print media is continuous length tape, the printing orientation is landscape and the page length is not specified, commands specifying the page format are ignored.

ESC (C Specify page length

| | | | | | | | |
|--------------|-----|----|----|----|----|----|----|
| ASCII: | ESC | (| C | nL | nH | mL | mH |
| Hexadecimal: | 1B | 28 | 43 | nL | nH | mL | mH |

Parameters

nL=2, nH=0

$0 \leq (mL + mH * 256) < 27575$ (for 203dpi printers)

$0 \leq (mL + mH * 256) < 35999$ (for 300dpi printers)

Description

- Specifies the page length.
 - * A page length 0 indicates the Auto setting.
- The unit is 1 dot.
 - Page length = mL + mH * 256
- The current paper position is the TOF.
- The top and bottom margins are canceled with ESC (c.
- All previously entered text is cleared.
- A standard unit is not used.
- This command is available only with continuous length tape.

Inch, mm, and dot conversion table

| inch | mm | Number of dots (203dpi) | Number of dots (300dpi) |
|------|-------|----------------------------|----------------------------|
| 0 | 0.0 | 0 | 0 |
| 1 | 25.4 | 203 | 300 |
| 2 | 50.8 | 406 | 600 |
| 3 | 76.2 | 609 | 900 |
| 4 | 101.6 | 812 | 1200 |
| 5 | 127.0 | 1015 | 1500 |
| 6 | 152.4 | 1218 | 1800 |
| 7 | 177.8 | 1421 | 2100 |
| 8 | 203.2 | 1624 | 2400 |
| 9 | 228.6 | 1827 | 2700 |
| 10 | 254.0 | 2030 | 3000 |
| 11 | 279.4 | 2233 | 3300 |
| 12 | 304.8 | 2436 | 3600 |
| 13 | 330.2 | 2639 | 3900 |
| 14 | 355.6 | 2842 | 4200 |
| 15 | 381.0 | 3045 | 4500 |
| 16 | 406.4 | 3248 | 4800 |
| 17 | 431.8 | 3451 | 5100 |
| 18 | 457.2 | 3654 | 5400 |
| 19 | 482.6 | 3857 | 5700 |
| 20 | 508.0 | 4060 | 6000 |

5.7 Printer control commands

ESC @ Initialize

| | | |
|--------------|-----|----|
| ASCII: | ESC | @ |
| Hexadecimal: | 1B | 40 |

Parameters

None

Description

- Returns all commands to their default settings. (See below.)

| Item | Default |
|-----------------------------|---|
| Input buffer | Saved |
| Text buffer | Cleared |
| Print buffer | Cleared |
| Top margin | 0 dot |
| Bottom margin | Depends on media |
| Left margin | 0 dot |
| Right margin | Depends on media |
| Line feed amount | 32 dots |
| Horizontal tab positions | Horizontal tab every 8 characters (based on a character width of 10 cpi) |
| Vertical tab positions | None |
| Character size | 21 dots |
| Character spacing | 0 dot |
| International character set | USA |
| Character style | Canceled |
| Compressed | Canceled |
| Horizontal print position | Top margin position (TOF position) |
| Vertical print position | Left margin position |
| Landscape setting | Canceled |
| Page length setting | Canceled |
| Font | Letter Gothic Bold |

ESC i U x Reboot

| | | | | |
|--------------|-----|----|----|----|
| ASCII: | ESC | i | U | x |
| Hexadecimal: | 1B | 69 | 55 | 78 |

Parameters

None

Description

- Reboot the printer.
- This is a raster command. Please change the mode before sending this command. Please refer to [ESC i a Switch command mode](#).

5.8 Graphics commands

ESC * Select bit image <for 203dpi printers>

| | | | | | | |
|--------------|-----|----|---|----|----|------|
| ASCII: | ESC | * | m | n1 | n2 | Data |
| Hexadecimal: | 1B | 2A | m | n1 | n2 | Data |

Parameters

m=0, 1, 2, 3, 4, 6, 32, 33, 38, 39

The image data is as follows:

- n1+n2*256 bytes when m=0, 1, 2, 3, 4, 6
- (n1+n2*256)*3 bytes when m=32, 33, 38, 39

Description

- Refer to "[ESC * Select bit image <for 300dpi printers>](#)" for 300dpi printers.
- Selects and outputs a bit image according to the value of m.
- n1 and n2 indicate the number of dot positions.

n1: The remainder from dividing the number of dot positions by 256

n2: The quotient from dividing the number of dot positions by 256

| m | Horizontal Dot Density | Vertical Dot Density | Horizontal Dot Resolution | Vertical Dot Resolution |
|----|------------------------|----------------------|---------------------------|-------------------------|
| 0 | 60 dpi | 60 dpi | 4/203 inch | 4/203 inch |
| 1 | 120 dpi | 60 dpi | 2/203 inch | 4/203 inch |
| 2 | 120 dpi | 60 dpi | 2/203 inch | 4/203 inch |
| 3 | 240 dpi | 60 dpi | 1/203 inch | 4/203 inch |
| 4 | 80 dpi | 60 dpi | 3/203 inch | 4/203 inch |
| 6 | 90 dpi | 60 dpi | 3/203 inch | 4/203 inch |
| 32 | 60 dpi | 180 dpi | 4/203 inch | 1/203 inch |
| 33 | 120 dpi | 180 dpi | 2/203 inch | 1/203 inch |
| 38 | 90 dpi | 180 dpi | 3/203 inch | 1/203 inch |
| 39 | 180 dpi | 180 dpi | 1/203 inch | 1/203 inch |

- Horizontally neighboring dots are not omitted.

Limitations:

A maximum of 63 can be used with this command.

The total size of the image data contained in one page must be 207,360 bytes or less.

When m=0, 1, 2, 3, 4, 6

- n1 and n2 indicate the number of dot positions.
 - n1: The remainder from dividing the number of dot positions by 256
 - n2: The quotient from dividing the number of dot positions by 256

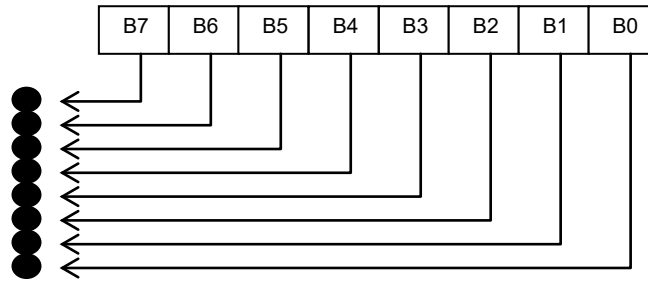

Relationship between the image data and the dots

- First, the data is lined up in one row as follows:

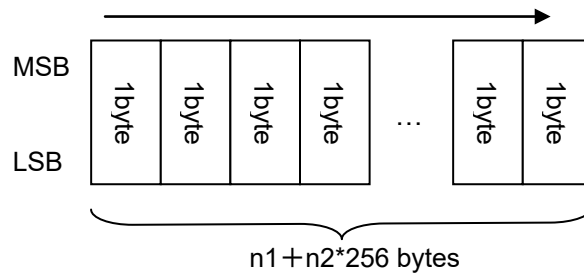

- One dot of the image data is enlarged as follows, according to the value of m.

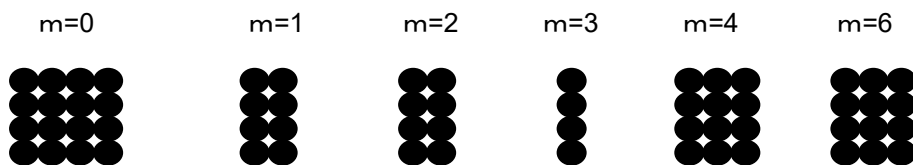

- As a result, the image is sized depending on the value of m, as follows:

| | |
|-----|--|
| m=0 | 32 dots vertically × (n1+n2*256)*4 dots horizontally |
| m=1 | 32 dots vertically × (n1+n2*256)*2 dots horizontally |
| m=2 | 32 dots vertically × (n1+n2*256)*2 dots horizontally |
| m=3 | 32 dots vertically × (n1+n2*256)*1 dots horizontally |
| m=4 | 32 dots vertically × (n1+n2*256)*3 dots horizontally |
| m=6 | 32 dots vertically × (n1+n2*256)*3 dots horizontally |

When m=32, 33, 38, 39

- n1 and n2 indicate the number of dot positions.
 - n1: The remainder from dividing the number of dot positions by 256
 - n2: The quotient from dividing the number of dot positions by 256

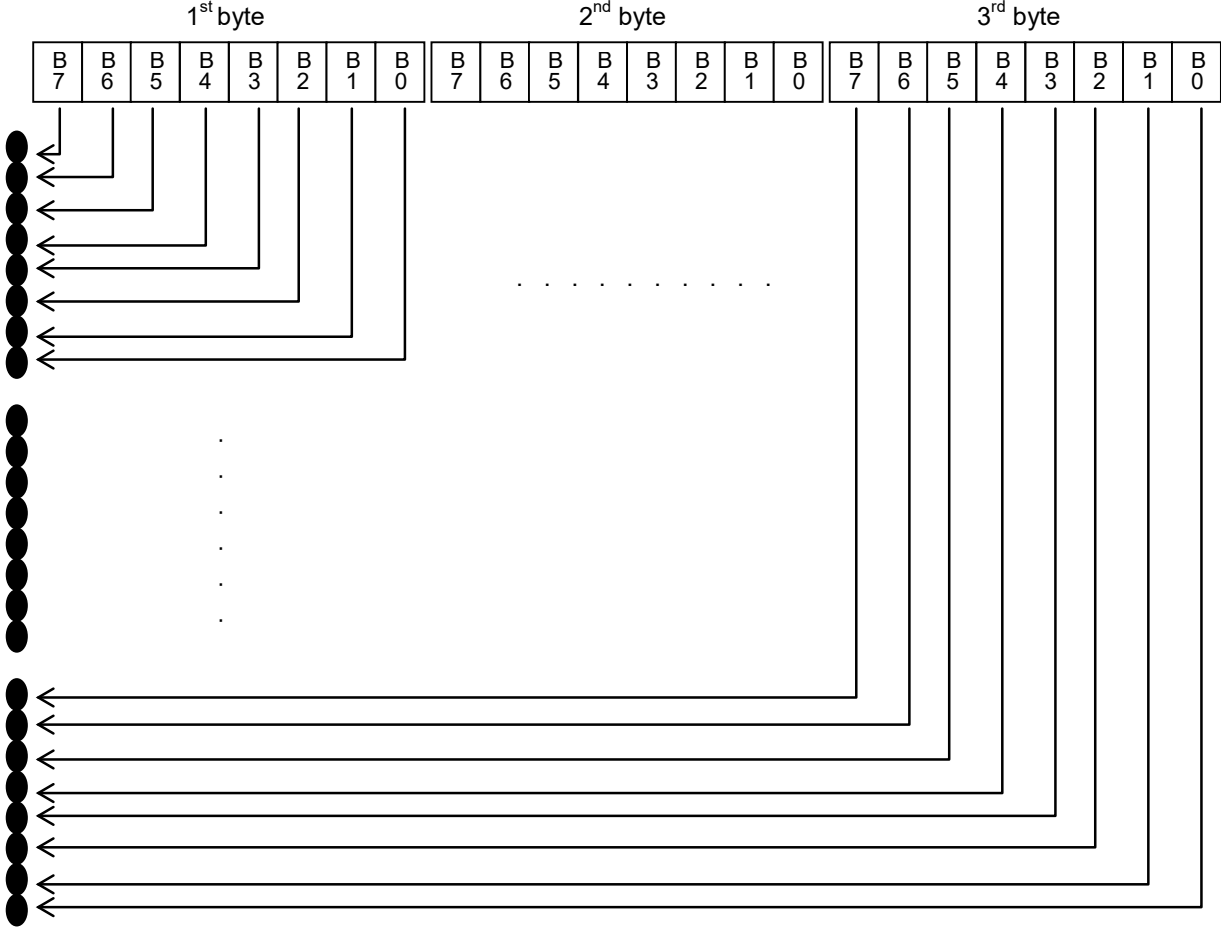

Relationship between the image data and the dots

First, the data is lined up in three rows as follows:

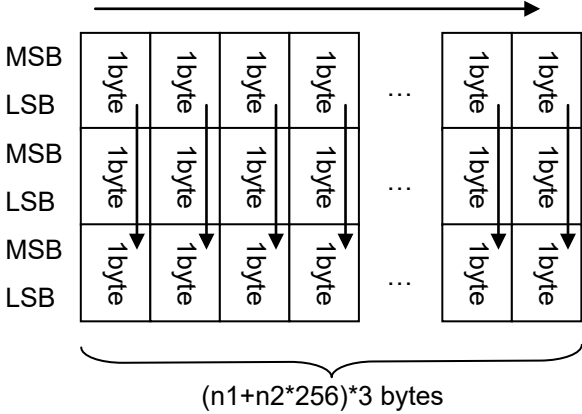

- One dot of the image data is enlarged as follows, according to the value of m.

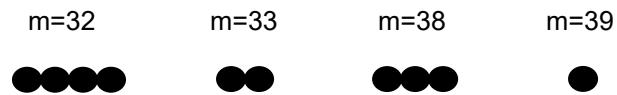

- As a result, the image is sized depending on the value of m, as follows:

m=32 24 dots vertically $\times (n1+n2 \times 256) \times 4$ dots horizontally

m=33 24 dots vertically $\times (n1+n2 \times 256) \times 2$ dots horizontally

m=38 24 dots vertically $\times (n1+n2 \times 256) \times 3$ dots horizontally

m=39 24 dots vertically $\times (n1+n2 \times 256) \times 1$ dots horizontally

ESC * Select bit image <for 300dpi printers>

| | | | | | | |
|--------------|-----|----|---|----|----|------|
| ASCII: | ESC | * | m | n1 | n2 | Data |
| Hexadecimal: | 1B | 2A | m | n1 | n2 | Data |

Parameters

m=0, 1, 2, 3, 4, 6, 32, 33, 38, 39, 40, 71, 72, 73

The image data is as follows:

- n1+n2*256 bytes when m=0, 1, 2, 3, 4, 6
- (n1+n2*256)*3 bytes when m=32, 33, 38, 39, 40
- (n1+n2*256)*6 bytes when m=71, 72, 73

Description

- Refer to "[ESC * Select bit image <for 203dpi printers>](#)" for 203dpi printers.
- Selects and outputs a bit image according to the value of m.
- n1 and n2 indicate the number of dot positions.
 - n1: The remainder from dividing the number of dot positions by 256
 - n2: The quotient from dividing the number of dot positions by 256

| m | Horizontal Dot Density | Vertical Dot Density | Horizontal Dot Resolution | Vertical Dot Resolution |
|----|------------------------|----------------------|---------------------------|-------------------------|
| 0 | 60 dpi | 60 dpi | 6/300 inch | 6/300 inch |
| 1 | 120 dpi | 60 dpi | 3/300 inch | 6/300 inch |
| 2 | 120 dpi | 60 dpi | 3/300 inch | 6/300 inch |
| 3 | 240 dpi | 60 dpi | 2/300 inch | 6/300 inch |
| 4 | 80 dpi | 60 dpi | 4/300 inch | 6/300 inch |
| 6 | 90 dpi | 60 dpi | 4/300 inch | 6/300 inch |
| 32 | 60 dpi | 180 dpi | 6/300 inch | 2/300 inch |
| 33 | 120 dpi | 180 dpi | 3/300 inch | 2/300 inch |
| 38 | 90 dpi | 180 dpi | 4/300 inch | 2/300 inch |
| 39 | 180 dpi | 180 dpi | 2/300 inch | 2/300 inch |
| 40 | 300 dpi | 180 dpi | 1/300 inch | 2/300 inch |
| 71 | 180 dpi | 360 dpi | 2/300 inch | 1/300 inch |
| 72 | 360 dpi | 360 dpi | 1/300 inch | 1/300 inch |
| 73 | 360 dpi | 360 dpi | 1/300 inch | 1/300 inch |

- Horizontally neighboring dots are not omitted.

Limitations:

A maximum of 63 can be used with this command.

The total size of the image data contained in one page must be 207,360 bytes or less.

When m=0, 1, 2, 3, 4, 6

- n1 and n2 indicate the number of dot positions.
 - n1: The remainder from dividing the number of dot positions by 256
 - n2: The quotient from dividing the number of dot positions by 256

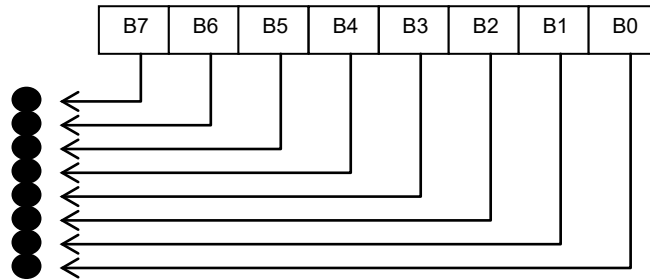

Relationship between the image data and the dots

- First, the data is lined up in one row as follows:

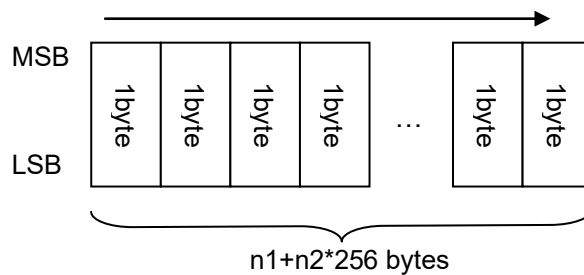

- One dot of the image data is enlarged as follows, according to the value of m.

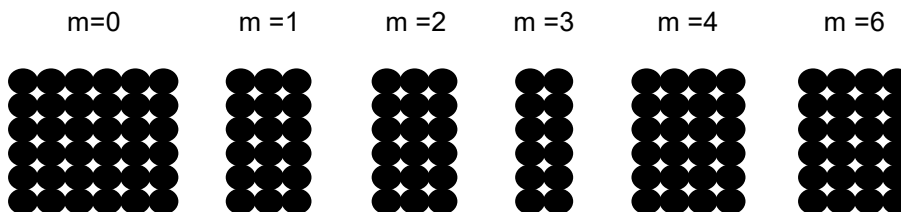

- As a result, the image is sized depending on the value of m, as follows:

- m=0 48 dots vertically×(n1+n2*256)*6 dots horizontally
- m=1 48 dots vertically×(n1+n2*256)*3 dots horizontally
- m=2 48 dots vertically×(n1+n2*256)*3 dots horizontally
- m=3 48 dots vertically×(n1+n2*256)*2 dots horizontally
- m=4 48 dots vertically×(n1+n2*256)*4 dots horizontally
- m=6 48 dots vertically×(n1+n2*256)*4 dots horizontally

When m=32, 33, 38, 39, 40

- n1 and n2 indicate the number of dot positions.
 - n1: The remainder from dividing the number of dot positions by 256
 - n2: The quotient from dividing the number of dot positions by 256

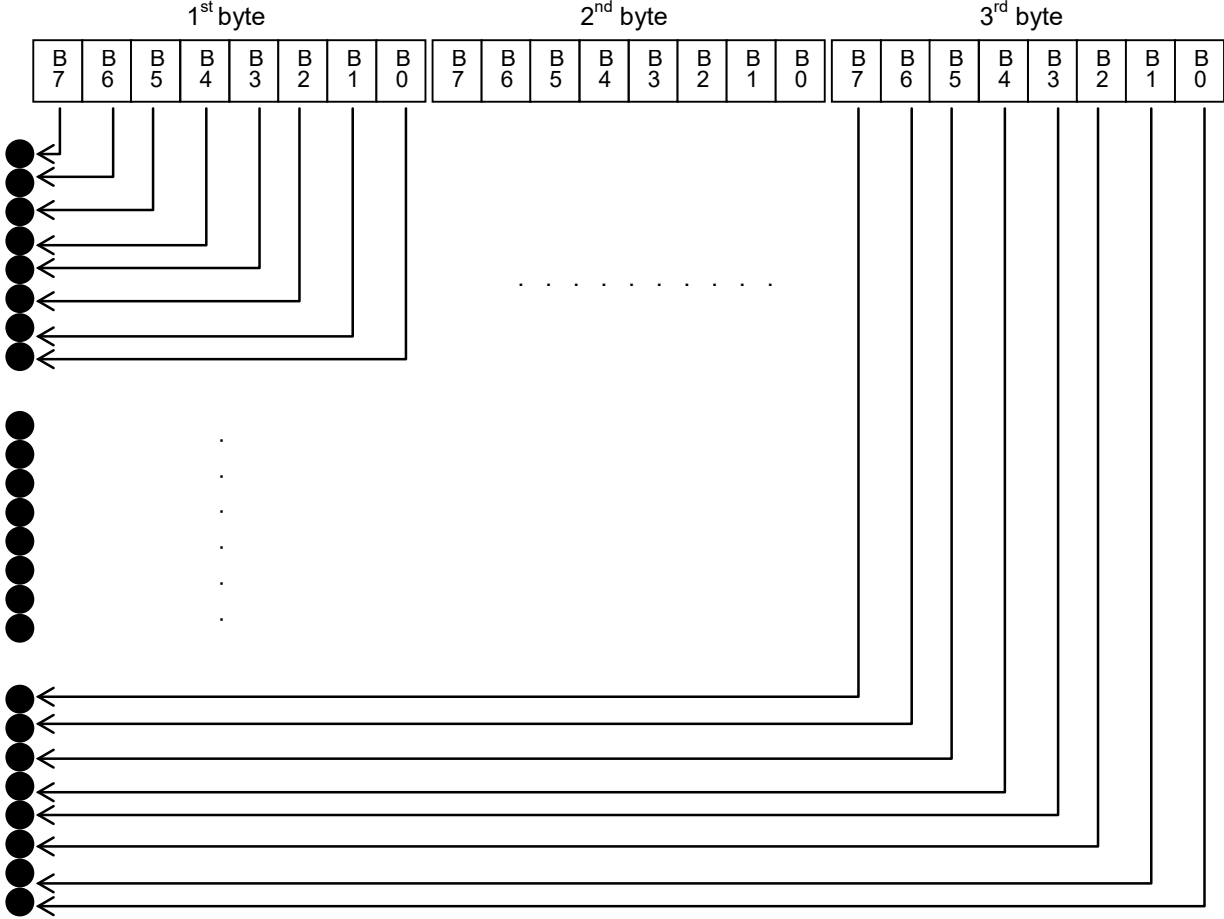

Relationship between the image data and the dots

First, the data is lined up in three rows as follows:

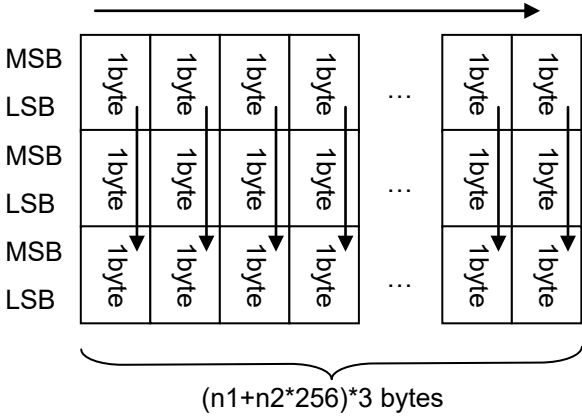

- One dot of the image data is enlarged as follows, according to the value of m.

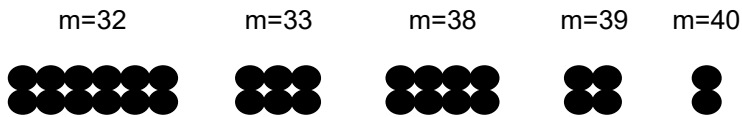

- As a result, the image is sized depending on the value of m, as follows:

| | |
|------|--|
| m=32 | 48 dots vertically × (n1+n2*256)*6 dots horizontally |
| m=33 | 48 dots vertically × (n1+n2*256)*3 dots horizontally |
| m=38 | 48 dots vertically × (n1+n2*256)*4 dots horizontally |
| m=39 | 48 dots vertically × (n1+n2*256)*2 dots horizontally |
| m=40 | 48 dots vertically × (n1+n2*256)*1 dot horizontally |

When m=71, 72, 73

- n1 and n2 indicate the number of dot positions.
 - n1: The remainder from dividing the number of dot positions by 256
 - n2: The quotient from dividing the number of dot positions by 256

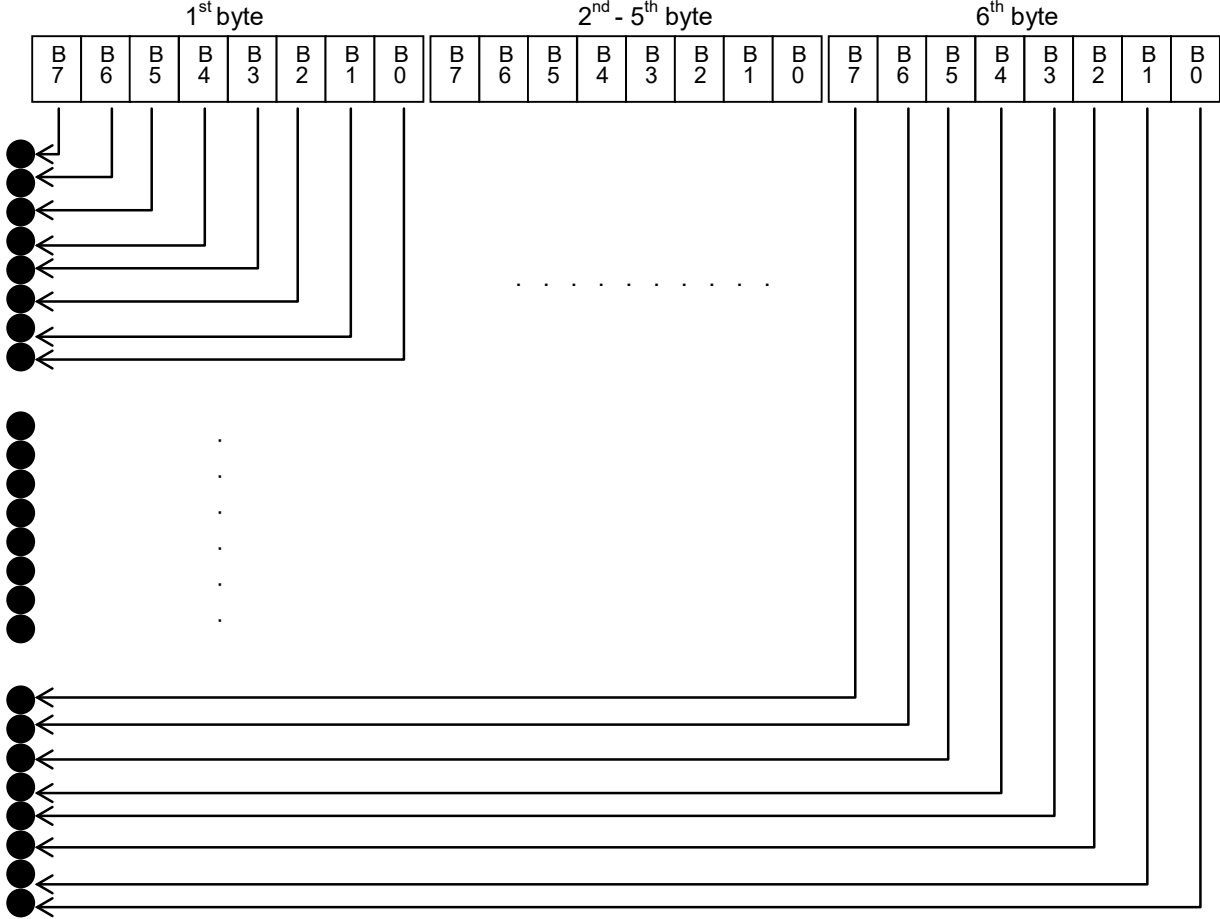

Relationship between the image data and the dots

First, the data is lined up in six rows as follows:

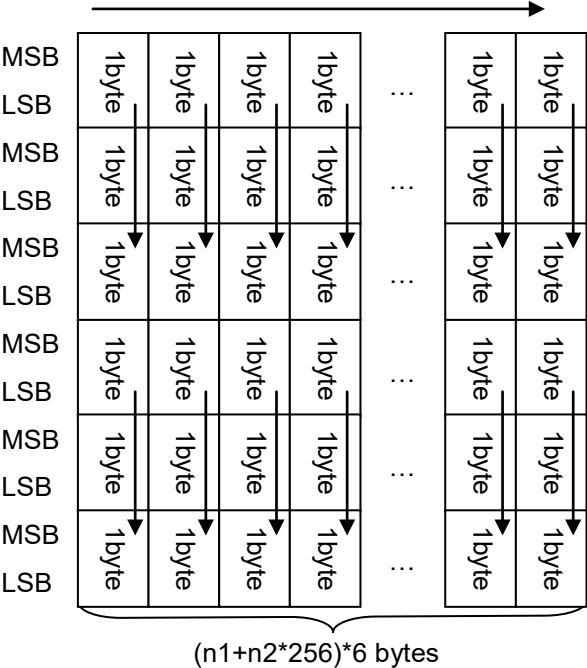

- One dot of the image data is enlarged as follows, according to the value of m.



- As a result, the image is sized depending on the value of m, as follows:

m=71 48 dots vertically \times $(n1+n2*256)*2$ dots horizontally
 m=72 48 dots vertically \times $(n1+n2*256)*1$ dot horizontally
 m=73 48 dots vertically \times $(n1+n2*256)*1$ dot horizontally

ESC K 8-dot single-density bit image

| | | | | | |
|--------------|-----|----|----|----|------|
| ASCII: | ESC | K | n1 | n2 | Data |
| Hexadecimal: | 1B | 4B | n1 | n2 | Data |

Parameters
 $0 \leq n1 \leq 255, 0 \leq n2 \leq 3$

The data contains $n1 + n2 * 256$ bytes of image data.

Description

Specifies that an 8-dot single-density bit image is printed with the number of dot positions indicated by n1 and n2.

- Same behavior as m=0 specified in ESC *.

ESC L 8-dot double-density bit image

| | | | | | |
|--------------|-----|----|----|----|------|
| ASCII: | ESC | L | n1 | n2 | Data |
| Hexadecimal: | 1B | 4C | n1 | n2 | Data |

Parameters
 $0 \leq n1 \leq 255, 0 \leq n2 \leq 3$

The data contains $n1 + n2 * 256$ bytes of image data.

Description

Specifies that an 8-dot double-density bit image is printed with the number of dot positions indicated by n1 and n2.

- Same behavior as m=1 specified in ESC *.

ESC Y 8-dot double-speed double-density bit image

| | | | | | |
|--------------|-----|----|----|----|------|
| ASCII: | ESC | Y | n1 | n2 | Data |
| Hexadecimal: | 1B | 59 | n1 | n2 | Data |

Parameters
 $0 \leq n1 \leq 255, 0 \leq n2 \leq 3$

The data contains $n1 + n2 * 256$ bytes of image data.

Description

- Same as for an 8-dot double-density bit image. Horizontally neighboring dots are not omitted.

ESC Z 8-dot quadruple-density bit image

| | | | | | |
|--------------|-----|----|----|----|------|
| ASCII: | ESC | Z | n1 | n2 | Data |
| Hexadecimal: | 1B | 5A | n1 | n2 | Data |

Parameters
 $0 \leq n1 \leq 255, 0 \leq n2 \leq 7$

The data contains $n1 + n2 * 256$ bytes of image data.

Description

Specifies that an 8-dot quadruple-density bit image is printed with the number of dot positions indicated by $n1$ and $n2$.

- Same behavior as $m=3$ specified in ESC *.
- Horizontally neighboring dots are not omitted.

5.9 Advanced commands

ESC i B Barcode

| | | | | |
|--------------|-----|-------------------------|------------------------------|--------------------|
| ASCII: | ESC | i [Parameters] | B or b [Barcode data] | Backslash |
| Hexadecimal: | 1B | 69 [Parameters] | 42 or 62 [Barcode data] | 5C |
| Format: | ESC | i [<u>Parameters</u>] | <u>B or b [Barcode data]</u> | <u>[Backslash]</u> |
| | | (1) | (2) (3) | (4) |

Parameters**(1) [Parameters]: Barcode parameters**

| | |
|--------------------------------------|--|
| T or t (type) | t0: CODE39 t1: ITF (I-2/5) t5: EAN-8, EAN-13, UPC-A t6: UPC-E t9: CODABAR ta: CODE128 tb: GS1-128 (UCC/EAN-128) tc: GS1 Databar(RSS) td: CODE93 te: POSTNET tf: UPC/EAN EXTENSION tg: MSI/Plessey th: Intelligent Mail Barcode |
| s (style) | Ignored |
| p (number of passes) | Ignored |
| R or r (characters below barcode) | r0: OFF r1: ON |
| u (units of measurement) | Ignored |
| x (horizontal position) | Ignored |
| y (vertical offset) | Ignored |

| | |
|--|---|
| h (height) | <p>h n1 n2 Height=$n1+n2*256$ (dots) $48 \leq \text{height} \leq 480$ If height<48, height=48. If height>480, height=480.</p> <p>However, the height is as shown below with tc. $131 \leq \text{height} \leq \text{Maximum width}$ (GS1 Databar Standard) $71 \leq \text{height} \leq \text{Maximum width}$ (GS1 Databar Truncated) $71 \leq \text{height} \leq \text{Maximum width}$ (GS1 Databar Stacked) $239 \leq \text{height} \leq \text{Maximum width}$ (GS1 Databar Stacked Omni) $62 \leq \text{height} \leq \text{Maximum width}$ (GS1 Databar Limited) $134 \leq \text{height} \leq \text{Maximum width}$ (GS1 Databar Expanded) If height<min., height=min. If height>max., height=max.</p> <p><i>Maximum width</i> depends on each models. Please refer to "Appendix B: Specifications".</p> <p>However, the height is as shown below with te. 203dpi : If height<48, height = 25. 300dpi : If height<48, height = 37.</p> <p>However, the height is as shown below with th. 203dpi : If height<48, height = 29. 300dpi : If height<48, height = 43.</p> |
| w (width) | w0: extra small w1: small w2: medium w3: large |
| E or e (parentheses deletion) | e0: ON e1: OFF |
| o (GS1 Databar symbols model) | o0: GS1 Databar Standard o1: GS1 Databar Truncated o2: GS1 Databar Stacked o3: GS1 Databar Stacked Omnidirectional o4: GS1 Databar Limited o5: GS1 Databar Expanded Standard o6: GS1 Databar Expanded Stacked |
| c (number of horizontal characters for GS1 Databar Expanded Stacked) | c: o. of horizontal characters This must be an even value where $2 \leq \text{no. of horizontal characters} \leq 20$. |
| z (ratio between thick and thin bars) | z0: (3:1) z1: (2.5:1) z2: (2:1) |
| f (equalize bar lengths) | f0: OFF f1: ON |

(A barcode with a large number of stacked rows may be considered out of specifications and unreadable by the reader.)

Note

- * For parameter numerals 0–9, both 00h–09h and 30h–39h are recognized.
- * For parameter type, both ‘a’-‘h’ and ‘A’-‘H’ are recognized.
- * The parameter “parentheses deletion” is available only when GS1-128 (UCC/EAN-128) is selected.
- * The parameter “ratio between thick and thin bars” is available only when t0, t1 or t9 is selected.
- * The parameter “equalize bar lengths” is available only when t5 or t6 is selected.
- * If any other type is selected, these parameters are ignored.
- * When there is no type command or an invalid type command has been specified, CODE39 is specified.
- * The number of characters that can be entered for each barcode type is as follows:
 - t0: 1–50 characters (“*” is not included)
 - t1: 1–64 characters
 - t5: 7 characters (for EAN-8)
12 characters (for EAN-13)
11 characters (for UPC-A)
 - t6: 6 characters
 - t9: 3–64 characters (Must begin and end with A, B, C, or D.)
 - ta: 1–64 characters
 - tb: 1–64 characters
 - tc: 3–15 characters (begins with “01”) (except with GS1 Databar Expanded)
Third digit is “0” or “1”. (for GS1 Databar Limited)
1–64 numbers or 1–40 letters* (for GS1 Databar Expanded)
* ISO646 characters can be printed.
(numbers, letters, spaces, !, ", %, &, ', (,), *, +, ,, -, ., /, :, ;, <, =, >, ? and _)
 - td: 1–64 characters
 - te: 5 characters, 9 characters, 11 characters
 - tf: 2 characters, 5 characters
 - tg: 1–14 characters
 - th: 20 characters, 25 characters, 29 characters, 31 characters (Second digit is “0”-“4”)

(2) B or b: Beginning of barcode data**(3) [Barcode data]: Barcode data**

? (Generate check digit):

Generates a check digit when “?” is in the barcode data.

The position of “?” is irrelevant as long as it is within the barcode data.

With POSTNET, CODE93, UPC/EAN EXTENSION, CODE128, GS1-128(UCC/EAN-128) and Intelligent Mail Barcode, no check digit is generated.

If “?” is inserted, it is treated as barcode data.

(4) [Backslash]: End of barcode

| Barcode Type | Command |
|---|---|
| POSTNET, UPC/EAN EXTENTION, CODE39, ITF(I-2/5), EAN-8, EAN-13, UPC-A, UPC-E, CODABAR, GS1 Databar , MSI/Plessey, Intelligent Mail Barcode | ESC i [Parameter] B or b [Barcode data] \ |
| CODE93, CODE128, GS1-128 (UCC/EAN-128) | ESC i [Parameter] B or b [Barcode data] \ \ |

Description

- Specifies a barcode image.
- Any data extending beyond the right margin is ignored.
- Since the check digit is generated automatically from the barcode data, the check digit is not sent as barcode data. Since the length of the barcode data is also checked, the data would not be correctly recognized if the check digit data was present.
- With CODE39, ITF (I-2/5), CODABAR, CODE128, GS1-128 (UCC/EAN-128) or GS1 Databar Expanded, the buffer length for the barcode image is about 22 cm. A barcode longer than 22 cm will not be printed.
- The characters that can be printed with CODE128 and GS1-128 (UCC/EAN-128) are the 128 ASCII characters and the special codes FNC1, FNC2, FNC3 and FNC4.

Codes assigned to the special codes:

FNC1: 86h

FNC2: 81h

FNC3: 80h

FNC4: 84h

- The control codes and special codes appear as spaces when characters are printed below CODE128 and GS1-128 (UCC/EAN-128) barcodes.
- Special code FNC1 can also be printed with GS1 Databar Expanded.
This special code also appears as a space when characters are printed below the barcode.

Code assigned to the special code:

FNC1: 86h

- With only UPC/EAN EXTENSION, the data is printed above the barcode.

Example

For barcode type CODE39, with no characters printed below the barcode, a size of large (width) × 480 dots (height), without parentheses, a ratio between thick and thin bars of 3:1, and bar lengths not equalized, the command will be as shown below.

```
ESC i t0 r0 w3 h E0h 01h e0 z0 f1 B 123456789 \
```

ESC i Q 2D barcode (QR Code)

| | | | | | | |
|--------------|-----|----|----------|---------------------|-----------------------|------------|
| ASCII: | ESC | i | Q or q | Data | | |
| Hexadecimal: | 1B | 69 | 51 or 71 | Data | | |
| Format: | ESC | i | Q or q | <u>[Parameters]</u> | <u>[Barcode data]</u> | <u> </u> |
| | | | | (1) | (2) | (3) |

Parameters**(1) [Parameters]**

Unlike with 1D barcodes, all parameters must be specified in order, starting from the top.

If a value other than those listed is entered for a parameter, that parameter is specified with its default value.

| | | |
|------------------------------|--|---|
| 1. Cell size | [1-byte decimal] 1–32 | Specifies the dot size per cell side. (The default value is 3.) |
| 2. Symbol type | [1-byte decimal] 1 [1-byte decimal] 2 [1-byte decimal] 3 | Model 1 Model 2 (default value) Micro QR |
| 3. Structured Append setting | [1-byte decimal] 0 [1-byte decimal] 1 | Not partitioned. (default value) Partitioned (*1) |
| 4. Code number | [1-byte decimal] 1–16 | Indicates the number of the symbol in a partitioned QR Code. |
| 5. Number of partitions | [1-byte decimal] 2–16 | Indicates the total number of symbols in a partitioned QR Code. |
| 6. Parity data | [1-byte hexadecimal] 00-FF | Value (in bytes) of exclusively OR'ing all the print data (print data before partition) |
| 7. Error correction level | [1-byte decimal] 1 [1-byte decimal] 2 [1-byte decimal] 3 [1-byte decimal] 4 | High-density level: L 7% Standard level: M 15% (default value) High-reliability level: Q 25% Ultra-high-reliability level: H 30% (*2) |
| 8. Data input method | [1-byte decimal] 0 [1-byte decimal] 1 | Auto input (default value) Manual input Selects whether numbers, English alphanumeric characters, kanji characters or binary characters are entered. |

(*1) With Micro QR, the Structured Append setting is invalid, and the default setting is used.

(*2) With Micro QR, error correction level 4 is invalid, and the default setting is used.

(*3) Some barcode readers cannot recognize a barcode with the cell size specified as 1 dot or 2 dots.

What is the QR Code Structured Append setting?

QR Codes have Structured Append settings.

A long character string can be partitioned into 2 to 16 partitions and printed.

With ESC/P commands, it is necessary to enter only the number of partitions.

For example, if the print data is partitioned into 3 partitions, the barcode data is as follows:

```
ESC i Q or q [1st parameter] [1st set of barcode data] \\\
ESC i Q or q [2nd parameter] [2nd set of barcode data] \\\
ESC i Q or q [3rd parameter] [3rd set of barcode data] \\\
```

Refer to the following for specifying settings for 3 through 6 in [Parameters].

3. Structured append setting: This determines whether or not the barcode data is partitioned. If the data is not partitioned, enter 0.
When not partitioning, the values of 4 (code number), 5 (number of partitions), and 6 (parity data) are ignored; therefore, enter 0 as a dummy value for these parameters.
4. Code number: This indicates which number the ESC/P command for that QR Code is.
For example, if it is for the second of four partitions, this is 2; for the fourth this is 4.
5. Number of partitions: This is the number of partitions.
6. Parity data: This is the value (in bytes) of exclusively OR'ing all the print data (print data before partition). Entering the same value as for the partitioned QR Code ESC/P command indicates that these codes are linked.

What is exclusive OR'ing in bytes?

The data is exclusively OR'ed (XOR'ed) in bytes and in order.

For example, putting a character string into hexadecimal gives 31h, 32h, 33h, 34h.

| Character | OR'ed (XOR'ed) in bytes | Results |
|--------------------|-------------------------|--|
| XOR of 31h and 32h | 0011 0001 ^= 0011 0010 | 0000 0011 (03h) |
| XOR of 03h and 33h | 0000 0011 ^= 0011 0011 | 0011 0000 (30h) |
| XOR of 30h and 34h | 0011 0000 ^= 0011 0100 | 0000 0100 (04h) Therefore, the parity is 04h. |

Note

If this parity value is incorrect, the correct QR Code is not generated.

Summary

Printing the character string “123456789” with a cell size of 4 dots, Model 2, standard error correction level, and automatic data input

| | |
|--|---|
| Without Structured Append | ESC i Q 04h 02h 00h 00h 00h 00h 02h 00h “123456789” \\\ |
| With Structured Append [Three partitions] | ESC i Q 04h 02h 01h 01h 03h 31h 02h 00h “123” \\\ ESC i Q 04h 02h 01h 02h 03h 31h 02h 00h “456” \\\ ESC i Q 04h 02h 01h 03h 03h 31h 02h 00h “789” \\\ (The parity for the character string “123456789” is 31h.) |

(2) [Barcode data]: Barcode data

When manual input is selected in 8 (data input method), the barcode data must be preceded with one of the following single-byte alphanumeric characters.

| Barcode Type | Preceded Character | Example |
|------------------------------|-----------------------|--|
| Number input | N or n | - |
| Alphanumeric character input | A or a | ESC i Q [other parameters] 1 A012345678aBcDe \\\ |
| Kanji character input | K or k | ESC i Q [other parameters] 1 K kanji character input \\\ |
| Binary character input | B or b+4-digit number | ESC i Q [other parameters] 1 B0005##### \\\ With the “4-digit number”, specify the number of binary characters to actually be entered. For example, if 12 binary characters are to be entered, specify: B 0012 (30h, 30h, 31h, 32h) |

The number of barcode data characters that can be entered depends on the model type and the input method.

| | |
|----------|--|
| Model 1 | 707 English alphanumeric characters, 1167 numbers, 486 binary bytes, 299 kanji characters |
| Model 2 | 4296 English alphanumeric characters, 7089 numbers, 2953 binary bytes, 1817 kanji characters |
| Micro QR | 21 English alphanumeric characters, 35 numbers, 15 binary bytes, 9 kanji characters |

Note

The numbers listed above are for an error correction level at a high-density level (L 7%).

If the standard level or higher is set, the number of characters that can be entered may decrease.

In addition, even if the characters are entered with the high-density level (L) specified, the number of characters that can be entered may decrease due to compression.

(3) \\\: End of barcode

There must be three backslashes to end 2D barcode.

Example

Refer to the section "[Summary](#)".

ESC i P QR Code version

| | | | | |
|--------------|-----|----|----|---|
| ASCII: | ESC | i | P | n |
| Hexadecimal: | 1B | 69 | 50 | n |

Parameters

$0 \leq n \leq 40$

Description

- The barcode size can be fixed.
- The default value is 0 (auto).
- The available versions differ depending on the symbol type used.

If a setting other than those listed is specified, the setting returns to its default.

The following settings are available for each symbol type.

Model1 (0–14), Model2 (0–40), MicroQR (0–4)

ESC i V 2D barcode (PDF417)

| | | | | | | |
|--------------|-----|----|----------|---------------------|-----------------------|------------|
| ASCII: | ESC | i | V or v | Data | | |
| Hexadecimal: | 1B | 69 | 56 or 76 | Data | | |
| Format: | ESC | i | V or v | <u>[Parameters]</u> | <u>[Barcode data]</u> | <u> </u> |
| | | | | (1) | (2) | (3) |

Parameters**(1) [Parameters]**

Unlike with 1D barcodes, all parameters must be specified in order, starting from the top.

If a value other than those listed is entered for a parameter, that parameter is specified with its default value.

| | | | |
|------------------------------------|------------------|------------------------------|--|
| 1. Cell size | [1-byte decimal] | 1 | Specifies the dot size per cell side. Prints 1 dot per cell side. |
| | [1-byte decimal] | 2 | Prints 2 dots per cell side. |
| | [1-byte decimal] | 3 | Prints 3 dots per cell side. (default value) |
| | [1-byte decimal] | 4 | Prints 4 dots per cell side. |
| | [1-byte decimal] | 5 | Prints 5 dots per cell side. |
| | [1-byte decimal] | 6 | Prints 6 dots per cell side. |
| | [1-byte decimal] | 8 | Prints 8 dots per cell side. |
| | [1-byte decimal] | 10 | Prints 10 dots per cell side. |
| 2. Symbol type | [1-byte decimal] | 0 | Standard (default value) |
| | [1-byte decimal] | 1 | Truncate |
| | [1-byte decimal] | 2 | MicroPDF417 standard |
| | [1-byte decimal] | 3 | MicroPDF417 Code128 emulation |
| 3. Data input method | [1-byte decimal] | 0 | Auto input (default value) |
| | [1-byte decimal] | 1 | Binary input |
| 4. Error correction capacity-type | [1-byte decimal] | 0 | Level input setting (default value) |
| | [1-byte decimal] | 1 | Percentage input setting |
| 5. Error correction capacity-value | | | |
| - Level input | [2-byte decimal] | 0–8 | Specifies the level. (The default value is 0.) |
| - Percentage input | [2-byte decimal] | 0–400 | Specifies the percentage. (The default value is 10.) |
| 6. Symbol size (X direction) | [1-byte decimal] | 0 | Auto setting (default value) |
| | [1-byte decimal] | 1–30 | Manual settings |
| | | *0 and 1–4 with MicroPDF417 | |
| 7. Symbol size (Y direction) | [1-byte decimal] | 0 | Auto setting (default value) |
| | [1-byte decimal] | 3–90 | Manual settings |
| | | *0 and 4–44 with MicroPDF417 | |

| | | |
|-----------------|-------------------------|---|
| 8. Aspect value | [2-byte decimal] 1–1000 | Specifies the aspect value. Actually, this is 0.01–10.0, but since the decimal point cannot be entered, a value multiplied by 100 is entered. The default value is 50. (The actual value is 0.5.) |
|-----------------|-------------------------|---|

Note

- * Some barcode readers cannot recognize a barcode with the cell size specified as 1 dot or 2 dots.
- * If a setting for the symbol size (X direction) or symbol size (Y direction) has been specified manually, the aspect value setting is ignored.
- * If a setting for the symbol size (X direction) or the symbol size (Y direction) has been entered manually, the bar code may not be printed or an unreadable bar code may be printed.
- * If both a large cell size and a high level error correction capacity have been specified, printing may not be possible due to a full print buffer.

[With symbol type MicroPDF417]

- * Since the error correction capacity is automatically determined from the symbol size (X direction) setting, the settings for “error correction capacity and type” and “error correction capacity-value” are ignored.
- * The aspect value setting is ignored.
- * The following table shows the values available for the symbol size (Y direction) according to the symbol size (X direction) setting. If an invalid setting is specified for the symbol size (Y direction), the default setting is specified.

| Symbol Size (X Direction) | Symbol Size (Y Direction) | | | | | | | | | | | |
|---------------------------|---------------------------|----|----|----|----|----|----|----|----|----|----|----|
| Auto | Auto | | | | | | | | | | | |
| 1 | Auto | 11 | 14 | 17 | 20 | 24 | 28 | | | | | |
| 2 | Auto | 8 | 11 | 14 | 17 | 20 | 23 | 26 | | | | |
| 3 | Auto | 6 | 8 | 10 | 12 | 15 | 20 | 26 | 32 | 38 | 44 | |
| 4 | Auto | 4 | 6 | 8 | 10 | 12 | 15 | 20 | 26 | 32 | 38 | 44 |

(2) Barcode data

The numbers of barcode data characters that can be entered are as follows.

1850 alphanumeric characters, 2710 numbers, 1108 binary bytes

Note

The numbers listed above are for an error correction level at a high-density level (L 7%). If the standard level or higher is set, the number of characters that can be entered may decrease. In addition, even if the characters are entered with the high-density level (L) specified, the number of characters that can be entered may decrease due to compression.

[With symbol type MicroPDF417]

Maximum of 250 alphanumeric characters, maximum of 366 numbers, maximum of 150 bytes of binary data

However, the following table shows the maximum amount of information allowed according to the settings for symbol size (X direction) and symbol size (Y direction).

| X | Y | Maximum Amount of Information Allowed | | |
|---|----|---------------------------------------|---------|--------|
| | | Alphanumeric Characters | Numbers | Binary |
| 1 | 11 | 6 | 8 | 3 |
| 1 | 14 | 12 | 17 | 7 |
| 1 | 17 | 18 | 26 | 10 |
| 1 | 20 | 22 | 32 | 13 |
| 1 | 24 | 30 | 44 | 18 |
| 1 | 28 | 38 | 55 | 22 |
| 2 | 8 | 14 | 20 | 8 |
| 2 | 11 | 24 | 35 | 14 |
| 2 | 14 | 36 | 52 | 21 |
| 2 | 17 | 46 | 67 | 27 |
| 2 | 20 | 56 | 82 | 33 |
| 2 | 23 | 64 | 93 | 38 |
| 2 | 26 | 72 | 105 | 43 |
| 3 | 6 | 10 | 14 | 6 |
| 3 | 8 | 18 | 26 | 10 |
| 3 | 10 | 26 | 38 | 15 |
| 3 | 12 | 34 | 49 | 20 |
| 3 | 15 | 46 | 67 | 27 |
| 3 | 20 | 66 | 96 | 39 |
| 3 | 26 | 90 | 132 | 54 |
| 3 | 32 | 114 | 167 | 68 |
| 3 | 38 | 138 | 202 | 82 |
| 3 | 44 | 162 | 237 | 97 |
| 4 | 4 | 14 | 20 | 8 |
| 4 | 6 | 22 | 32 | 13 |
| 4 | 8 | 34 | 49 | 20 |
| 4 | 10 | 46 | 67 | 27 |
| 4 | 12 | 58 | 85 | 34 |
| 4 | 15 | 76 | 111 | 45 |
| 4 | 20 | 106 | 155 | 63 |
| 4 | 26 | 142 | 208 | 85 |
| 4 | 32 | 178 | 261 | 106 |
| 4 | 38 | 214 | 313 | 128 |
| 4 | 44 | 250 | 366 | 150 |

(3) \\\: End of barcode

There must be three backslashes to end 2D barcodes.

ESC i D 2D barcode (DataMatrix)

| | | | | | | |
|--------------|-----|----|----------|---------------------|-----------------------|------------|
| ASCII: | ESC | i | D or d | data | | |
| Hexadecimal: | 1B | 69 | 44 or 64 | data | | |
| Format: | ESC | i | D or d | <u>[Parameters]</u> | <u>[Barcode data]</u> | <u>\\\</u> |
| | | | | (1) | (2) | (3) |

Parameters**(1) [Parameters]**

Unlike with 1D barcodes, all parameters must be specified in order, starting from the top.

If a value other than those listed is entered for a parameter, that parameter is specified with its default value.

| | | |
|------------------|--|--|
| 1. Cell size | [1-byte decimal] 1 [1-byte decimal] 2 [1-byte decimal] 3 [1-byte decimal] 4 [1-byte decimal] 5 [1-byte decimal] 6 [1-byte decimal] 8 [1-byte decimal] 10 | Specifies the dot size per cell side. Prints 1 dot per cell side. Prints 2 dots per cell side. Prints 3 dots per cell side. (default value) Prints 4 dots per cell side. Prints 5 dots per cell side. Prints 6 dots per cell side. Prints 8 dots per cell side. Prints 10 dots per cell side. |
| 2. Symbol type | [1-byte decimal] 0 [1-byte decimal] 1 | ECC200 square (default value) ECC200 rectangular |
| 3. Vertical size | [1-byte decimal] 0 [1-byte decimal] 10 [1-byte decimal] 12 [1-byte decimal] 14 [1-byte decimal] 16 [1-byte decimal] 18 [1-byte decimal] 20 [1-byte decimal] 22 [1-byte decimal] 24 [1-byte decimal] 26 [1-byte decimal] 32 [1-byte decimal] 36 [1-byte decimal] 40 [1-byte decimal] 44 [1-byte decimal] 48 [1-byte decimal] 52 [1-byte decimal] 64 [1-byte decimal] 72 [1-byte decimal] 80 [1-byte decimal] 88 [1-byte decimal] 96 (continued to the next page) | [ECC200 square] Vertical no. of cells: AUTO (default value) Vertical no. of cells: 10 cells Vertical no. of cells: 12 cells Vertical no. of cells: 14 cells Vertical no. of cells: 16 cells Vertical no. of cells: 18 cells Vertical no. of cells: 20 cells Vertical no. of cells: 22 cells Vertical no. of cells: 24 cells Vertical no. of cells: 26 cells Vertical no. of cells: 32 cells Vertical no. of cells: 36 cells Vertical no. of cells: 40 cells Vertical no. of cells: 44 cells Vertical no. of cells: 48 cells Vertical no. of cells: 52 cells Vertical no. of cells: 64 cells Vertical no. of cells: 72 cells Vertical no. of cells: 80 cells Vertical no. of cells: 88 cells Vertical no. of cells: 96 cells |

| | | |
|---------------------------------|--|--|
| 3. Vertical size (continued) | (continued from the previous page) [1-byte decimal] 104 [1-byte decimal] 120 [1-byte decimal] 132 [1-byte decimal] 144 [1-byte decimal] 0 [1-byte decimal] 8 [1-byte decimal] 12 [1-byte decimal] 16 | Vertical no. of cells: 104 cells Vertical no. of cells: 120 cells Vertical no. of cells: 132 cells Vertical no. of cells: 144 cells [ECC200 rectangular] Vertical no. of cells: AUTO (default value) Vertical no. of cells: 8 cells Vertical no. of cells: 12 cells Vertical no. of cells: 16 cells |
| 4. Horizontal size | [1-byte decimal] x [1-byte decimal] 0 [1-byte decimal] 18 [1-byte decimal] 32 [1-byte decimal] 26 [1-byte decimal] 36 [1-byte decimal] 36 [1-byte decimal] 48 | [ECC200 square] Horizontal no. of cells: Same value as vertical size (x) [ECC200 rectangular] (1) When the vertical size is AUTO Horizontal no. of cells: AUTO (default value) (2) When the vertical size is 8 cells Horizontal no. of cells: 18 cells Horizontal no. of cells: 32 cells (3) When the vertical size is 12 cells Horizontal no. of cells: 26 cells Horizontal no. of cells: 36 cells (4) When the vertical size is 16 cells Horizontal no. of cells: 36 cells Horizontal no. of cells: 48 cells |
| 5. Reserved | [1-byte decimal]×5 0 | 5 bytes of dummy data (0) is sent. |

Note

Some barcode readers cannot recognize a barcode with the cell size specified as 1 dot or 2 dots. If the vertical size is specified as a value other than those listed for ECC200 square, the AUTO setting is selected. If the horizontal size is specified as a value different from the vertical size, the setting is changed to the same value as the horizontal size.

If the vertical or horizontal size for ECC200 rectangular is specified as a value other than those listed, the AUTO setting is selected.

(2) [Barcode data]: Barcode data

The maximum number of barcode data characters that can be entered is listed below.

2335 alphanumeric characters, 3116 numbers, 1556 bytes of binary data

Note

The numbers of characters that can be entered (as listed above) are for the maximum vertical × horizontal cell settings (144 cells × 144 cells). The number of characters that can be entered may decrease, depending on the specified settings.

(3) \\\: End of barcode

There must be three backslashes to end 2D barcodes.

Example

For data "12345" with symbol type ECC square at 40 × 40 with a 3-dot cell size, the command will be as shown below.

```
ESC i D 03h 00h 28h(40d) 28h 00h 00h 00h 00h "12345" \\\
```

ESC i M 2D barcode (MaxiCode)

| | | | | |
|--------------|-----|----|----------|--|
| ASCII: | ESC | i | M or m | data |
| Hexadecimal: | 1B | 69 | 4D or 6D | data |
| Format: | ESC | i | M or m | <u>[Parameters]</u> \ <u>[Barcode data]</u> <u> </u> |
| | | | (1) | (2) (3) (4) |

Parameters**(1) [Parameters]**

If a value other than those listed is entered for a parameter, that parameter is specified with its default value.

| | | | |
|------------------------------|------------------|---|---|
| 1. Symbol type | [1-byte decimal] | 0 | Standard (default value) |
| | [1-byte decimal] | 1 | Full EEC |
| | [1-byte decimal] | 2 | Structured carrier message |
| 2. Structured Append setting | [1-byte decimal] | 0 | With Structured Append (default value) |
| | [1-byte decimal] | 1 | Without Structured Append |

(2) \ (backslash)

Separator between parameters and barcode data

(3) [Barcode data]: Barcode data

The number of barcode data characters that can be entered is listed below.

| Symbol Type | Maximum Amount of Information Allowed | |
|----------------------------|---------------------------------------|---------|
| | Alphanumeric Characters | Numbers |
| Standard | 93 | 138 |
| Full EEC | 77 | 113 |
| Structured carrier message | 84 | 126 |

Note

The numbers of characters that can be entered (as listed above) are for when using only the common character set (code set A in the MaxiCode specifications). The number of characters that can be entered may decrease, depending on the characters that are used.

When the symbol type is the structured carrier message, the service class, country code and postal code can be specified separately from the normal data. Specify each value, separated by a backslash and comma (\,), immediately before the normal data.

<postal_code>\,<country_code>\,<service_class>\,<normal_barcode_data>

When “\,” is not used three times, the data is written as shown in the following example.

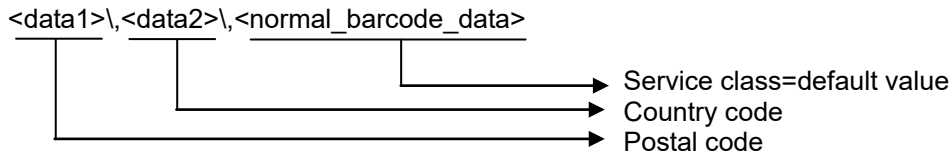

If a value other than those listed is entered for a parameter, that parameter is specified with its default value.

| | | |
|---------------|--|--|
| Postal code | 9 or less numbers, or 6 or less alphanumeric characters | Ignored when not structured carrier message. Default value: 00000000 |
| Country code | 3 or less numbers | Ignored when not structured carrier message. Default value: 000 |
| Service class | 3 or less numbers | Ignored when not structured carrier message. Default value: 000 |

Note

If the postal code is specified as alphanumeric characters, characters other than those listed below are invalid.

A to Z “ # \$ % & ‘ () * + , - . / 0 to 9 :

However, lowercase letters (a to z) are converted to the valid uppercase letters (A to Z).

(4) \\\: End of barcode

There must be three backslashes to end 2D barcodes.

ESC i J 2D barcode (Aztec)

| | | | | | | |
|--------------|-----|----|----------|---------------------|-----------------------|------------|
| ASCII: | ESC | i | J or j | data | | |
| Hexadecimal: | 1B | 69 | 4A or 6A | data | | |
| Format: | ESC | i | J or j | <u>[Parameters]</u> | <u>[Barcode data]</u> | <u>\\\</u> |
| | | | | (1) | (2) | (3) |

Parameters**(1) [Parameters]**

If a value other than those listed is entered for a parameter, that parameter is specified with its default value.

| | | |
|---|---|--|
| 1. Cell size | [1-byte decimal] 1 [1-byte decimal] 2 [1-byte decimal] 3 [1-byte decimal] 4 [1-byte decimal] 5 [1-byte decimal] 6 [1-byte decimal] 8 [1-byte decimal] 10 | Specifies the dot size per cell side. Prints 1 dot per cell side. Prints 2 dots per cell side. Prints 3 dots per cell side. (default value) Prints 4 dots per cell side. Prints 5 dots per cell side. Prints 6 dots per cell side. Prints 8 dots per cell side. Prints 10 dots per cell side. |
| 2. Symbol type | [1-byte decimal] 0 [1-byte decimal] 1 [1-byte decimal] 2 | Full range (default value) Compact Auto setting |
| 3. Error correction capacity | [1-byte decimal] 1–99 | Percentage (default value is 23) |
| 4. Symbol size | [Full range] [1-byte decimal] 0 [1-byte decimal] 4–32 [Compact] [1-byte decimal] 0 [1-byte decimal] 1–4 | Auto setting (default value) Manual settings Auto setting (default value) Manual settings |
| Note: Symbol size is fixed as AUTO when Symbol type is specified as AUTO. | | |
| 5. Structured Append setting | [1-byte decimal] 0 [1-byte decimal] 1 [1-byte decimal] 2 | Not partitioned. (default value) Partitioned Partitioned Specify the number of blocks |
| 6. Number of blocks | [1-byte decimal] 2–26 | Partitioned Only valid when the number of blocks is specified (Default it 2) |
| 7. Message ID | Character string (Terminal value is 00h) | Invalid when append setting 0. |

(2) [Barcode data]: Barcode data

The maximum number of barcode data characters that can be entered is listed below.

3067 alphanumeric characters, 3832 numbers, 1914 bytes of binary data

Note

The number of characters shown above is only for the Full-Range mode and varies depending on setting.

(3) \\\: End of barcode

There must be three backslashes to end 2D barcodes.

ESC i G Specify font

| | | | | | | |
|--------------|-----|----|----|-----|----|------|
| ASCII: | ESC | i | G | 00h | n1 | data |
| Hexadecimal: | 1B | 69 | 47 | 00 | n1 | data |

Parameters
 $1 \leq n1 \leq 16$
Description

● Specify font

n1: Specify the length of character string of specified font name.

Data: Character string of font name.

Example

For specifying "HelOb.FNT".

```
ESC i G 00h 09h HelOb.FNT
```

ESC i F P Print downloaded data

| | | | | | |
|--------------|-----|----|----|----|---|
| ASCII: | ESC | i | F | P | n |
| Hexadecimal: | 1B | 69 | 46 | 50 | n |

Parameters

n: Minus 1 from the key number assigned when transport the data.

0 ≤ n ≤ 254

Description

- Print a transferred image on a current print position.
- If there is no image data, this command is ignored.

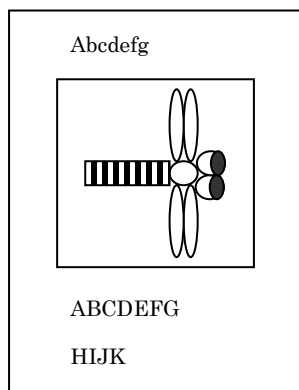
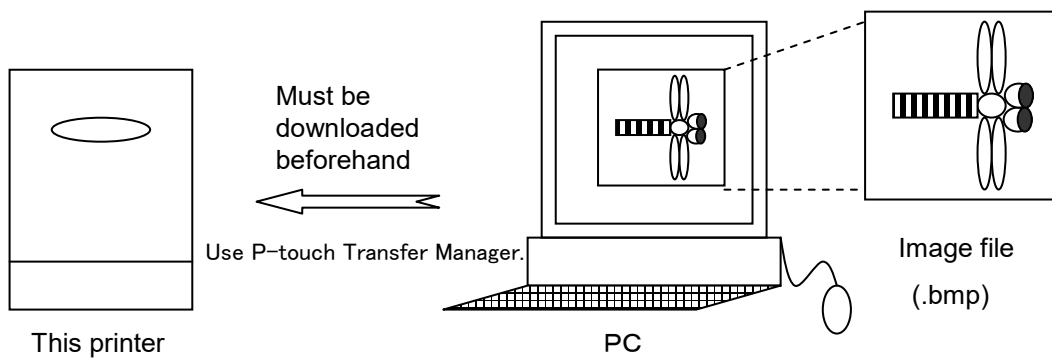

Example: Combination of text and downloaded image

- As with text, if the image data does not all fit on the current line, an automatic line feed is performed, and the data is placed at the beginning of the next line. At that time, the any data that does not fit in the print area is deleted.

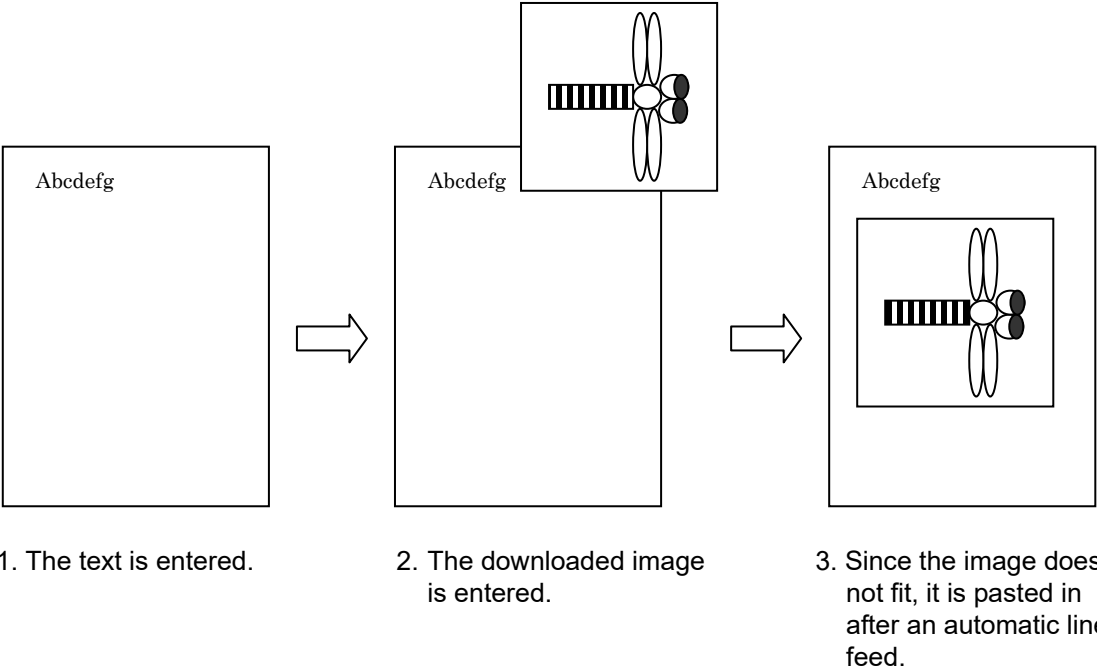

Example: Normal size

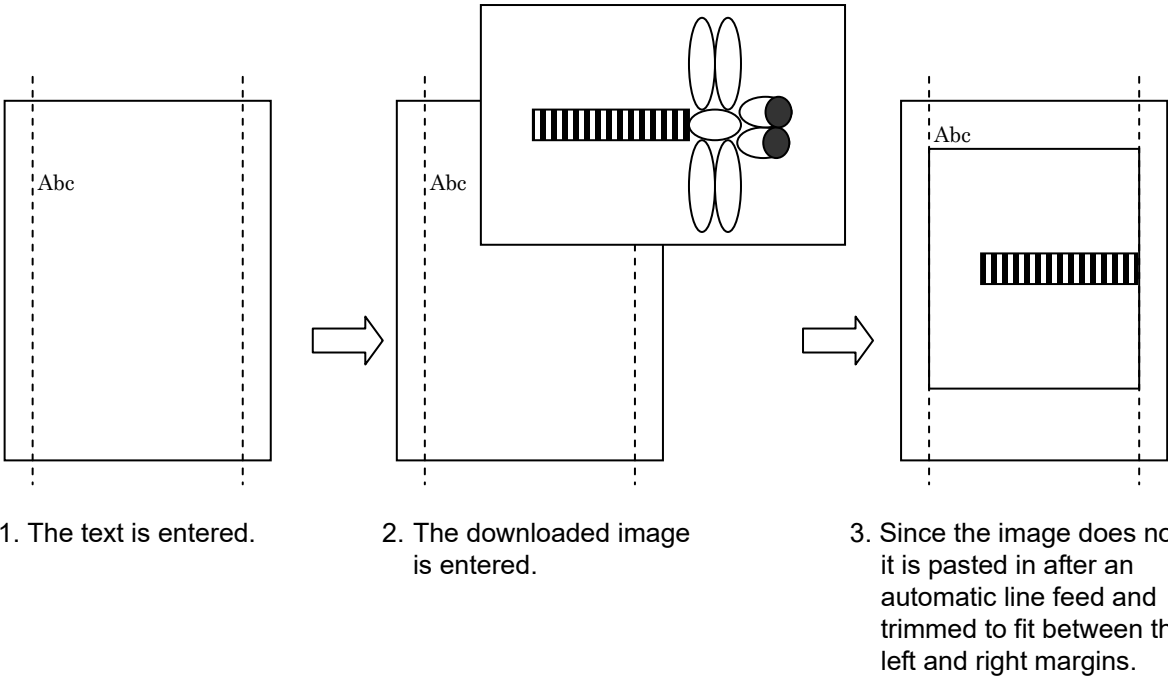

Example: Image larger than the distance between left and right margins

- If the result of pasting in the downloaded image extends beyond the bottom margin position, the image is pasted in after a page feed. At that time, the any data that does not fit in the print area is deleted.

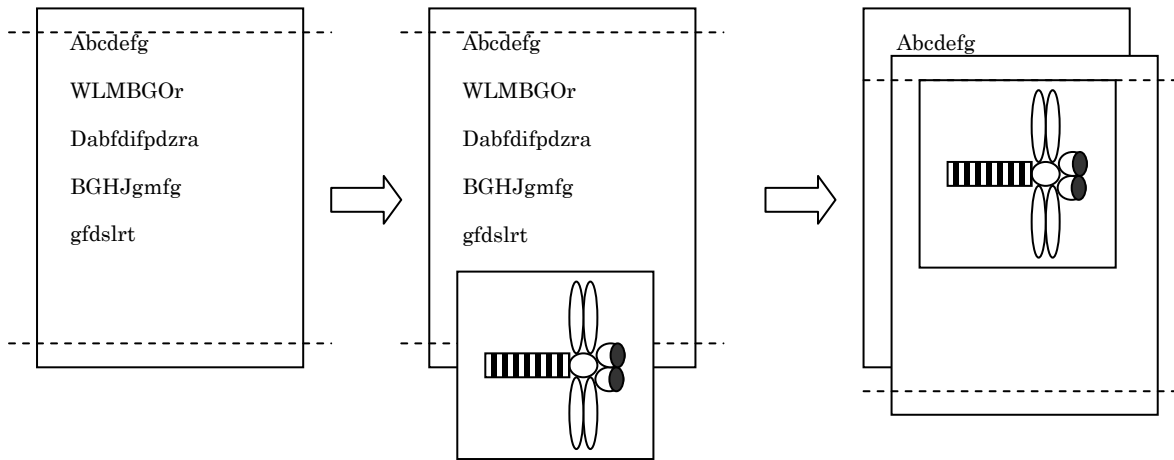

1. The text is entered.

2. The downloaded image is entered.

3. Since the image does not fit, it is pasted in after an automatic page feed.

Example: Image smaller than the distance between the top and bottom margins

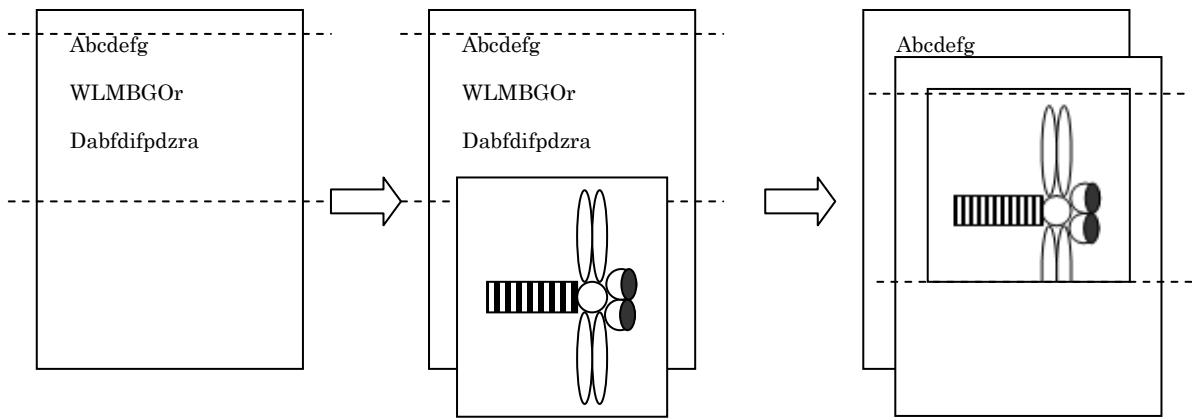

1. The text is entered.

2. The downloaded image is entered.

3. Since the image does not fit, it is pasted in after an automatic page feed and trimmed to fit between the top and bottom margins.

Example: Image larger than the distance between top and bottom margins

- An image data used by “ESC i F P” has to be registered into a printer first. Use P-touch Transfer Manager for transferring the BMP file to a printer for image data registration. A maximum size of memory is different from each model. Please refer to [Appendix B: Specifications](#) for model-specific information.
- Image data larger than the media size is handled by deleting the portion of the image that does not fit within the size of the media.

The portion of image data deleted depends on the media orientation.

ESC i a Switch command mode

| | | | | |
|--------------|-----|----|----|---|
| ASCII: | ESC | i | a | n |
| Hexadecimal: | 1B | 69 | 61 | n |

Parameters

- n: Command mode
- 00h or 30h ('0'): ESC/P standard mode
 - 01h or 31h ('1'): Raster graphics mode
 - 03h or 33h ('3'): P-touch Template mode
 - 04h or 34h ('4'): CPCL Page Print mode
 - 05h or 35h ('5'): CPCL Line Print mode
 - 07h or 37h ('7'): EPL emulation mode
 - 08h or 38h ('8'): DPL emulation mode
 - FFh: Switch to the initial mode (power-on default)

Description

- Switches the command execution mode.
- Dynamically switches between the five modes.
- Since this is a dynamic command, after the printer is turned off and on again, the setting returns to the previously setting.
- Invalid if n is a value outside of the allowable range.

ESC i S Status information request

| | | | |
|--------------|-----|----|----|
| ASCII: | ESC | i | S |
| Hexadecimal: | 1B | 69 | 53 |

Parameters

None

Description

- Returns the printer status. The printer status consists of 32 bytes.
- The printer does not return status during the printing operation.

| Offset | Name | Value/Standard |
|--------|-----------------------------------|---|
| 0 | Print head mark | Fixed at 80h |
| 1 | Size | Fixed at 20h |
| 2 | Brother code | Fixed at "B" (42h) |
| 3 | Series code | Refer to table (6) below. |
| 4 | Model code | Refer to table (7) below. |
| 5 | Country code | Fixed at "0" (30h) |
| 6 | Power status | Refer to table (5) below. |
| 7 | Reserved | Fixed at 00h |
| 8 | Error information 1 | Refer to table (1) below. |
| 9 | Error information 2 | Refer to table (2) below. |
| 10 | Media width | Refer to " 3.1 Print area " on page 11. |
| 11 | Media type | Refer to table (3) below. |
| 12 | Number of colors | Fixed at 00h |
| 13 | Media length (higher order bytes) | Refer to " 3.1 Print area " on page 11. |
| 14 | Media sensor value | Not used |
| 15 | Mode | Fixed at 01h |
| 16 | Density | Fixed at 00h |
| 17 | Media length (lower order bytes) | Refer to " 3.1 Print area " on page 11. |
| 18 | Status type | Refer to table (4) below. |
| 19 | Phase type | Fixed at 00h |
| 20 | Phase number (higher order bytes) | Fixed at 00h |
| 21 | Phase number (lower order bytes) | Fixed at 00h |
| 22 | Notification number | Not used |
| 23 | Expansion area (number of bytes) | Fixed at 00h |
| 24-31 | Reserved | Fixed at 00h |

(1) Error information 1

| Flag | Mask | Meaning |
|-------|------|---|
| Bit 0 | 01h | Not used |
| Bit 1 | 02h | “End of media” error/“Out of paper” error |
| Bit 2 | 04h | Not used |
| Bit 3 | 08h | Battery weak/“Charge needed” error |
| Bit 4 | 10h | Not used |
| Bit 5 | 20h | Printer turned off |
| Bit 6 | 40h | Not used |
| Bit 7 | 80h | Not used |

(2) Error information 2

| Flag | Mask | Meaning |
|-------|------|--|
| Bit 0 | 01h | Not used |
| Bit 1 | 02h | “Expansion buffer full” error |
| Bit 2 | 04h | Communication error |
| Bit 3 | 08h | Not used |
| Bit 4 | 10h | “Cover open” error |
| Bit 5 | 20h | Not used |
| Bit 6 | 40h | Leading edge detection error/Paper error |
| Bit 7 | 80h | System error |

(3) Media type

| Media Type | Value | Remarks |
|----------------------------------|-------|---------|
| Continuous length tape | 4Ah | |
| Die-cut label / Media with marks | 4Bh | |

(4) Status type

| Status Type | Value | Remarks |
|-------------------------|-----------|---|
| Reply to status request | 00h | |
| (Not used) | 01h | |
| Error occurred | 02h | For error types, see Error Information 1/2. |
| (Not used) | 03h - FFh | |

(5) Power status

(RJ-4XXX, RJ-3XXX)

| Value | Battery level | AC adapter |
|-------|-------------------|---------------|
| 20h | Full | Not connected |
| 21h | High | Not connected |
| 22h | Half | Not connected |
| 23h | Low | Not connected |
| 24h | Charging required | Not connected |
| 30h | Full | Connected |
| 31h | High | Connected |
| 32h | Half | Connected |
| 33h | Low | Connected |
| 34h | Charging required | Connected |
| 37h | No battery | Connected |
| Other | Undefined | Undefined |

(TD-4XXX)

| Value | Meaning |
|-------|-------------------|
| 37h | AC adapter in use |

(RJ-3XXX, RJ-2XXX, TD-2XXX)

| Value | Meaning |
|-------|-------------------|
| 00h | Full battery |
| 01h | Half battery |
| 02h | Low battery |
| 03h | Charging required |
| 04h | AC adapter in use |

(6) Series code

| Series | Value | Remarks |
|---------------------------|----------|---------|
| RJ-4XXX, RJ-3XXX, RJ-2XXX | "7"(37h) | |
| TD-4XXX, TD-2XXX | "5"(35h) | |

(7) Model code

| Model | Value | Remarks |
|-------------|-----------|---------|
| RJ-4230B | "C"(43h) | |
| RJ-4250WB | "D"(44h) | |
| RJ-3230B | "E" (45h) | |
| RJ-3250WB | "F" (46h) | |
| RJ-2030 | "6" (36h) | |
| RJ-2050 | "7" (37h) | |
| RJ-2140 | "8" (38h) | |
| RJ-2150 | "9" (39h) | |
| TD-4410D | "7"(37h) | |
| TD-4420DN | "8"(38h) | |
| TD-4510D | "9"(39h) | |
| TD-4520DN | "A"(41h) | |
| TD-4550DNWB | "B"(42h) | |
| TD-4210D | "C" (43h) | |
| TD-2020 | "3" (33h) | |
| TD-2120N | "5" (35h) | |
| TD-2130N | "6" (36h) | |

ESC i L Specify landscape orientation

| | | | | |
|--------------|-----|----|----|---|
| ASCII: | ESC | i | L | n |
| Hexadecimal: | 1B | 69 | 4C | n |

Parameters

n=0, 1 or 48, 49

Description

- Applies or cancels the landscape orientation
 - n=1 or 49 ("1"): Applies the landscape orientation.
 - n=0 or 48 ("0"): Cancels the landscape orientation.
- Using this command clears all text.
- Before entering text, specify the paper orientation with this command.
- The setting specified by "ESC iXL2"(default landscape setting) is valid for the landscape orientation when the printer is turned on.

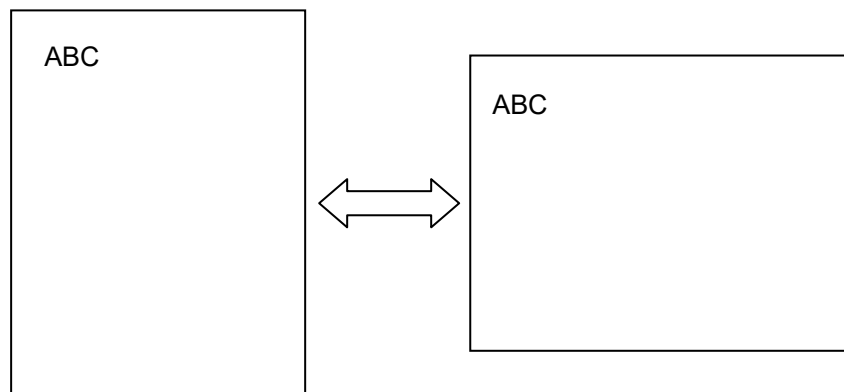

ESC i C Specify cutting

| | | | | |
|--------------|-----|----|----|---|
| ASCII: | ESC | i | C | n |
| Hexadecimal: | 1B | 69 | 43 | n |

Parameters

n=0, 1 or 48, 49

Description

- Specifies cutting after printing.
 - n=1 or 49 ("1"): Specifies cutting.
 - n=0 or 48 ("0"): Cancels cutting.
- This command is applied to only a printer with auto cutter.
- The default auto cut setting can be changed with the P-touch Template Settings Tool (P-touch Template Settings.exe).
- The number of auto cut copies can be specified with the P-touch Template Settings Tool (P-touch Template Settings.exe).
- Manufacturer's default auto cut setting: ON (auto cut)
 Manufacturer's default auto cut copies: 1

ESC i H Specify recovery setting

| | | | | |
|--------------|-----|----|----|----|
| ASCII: | ESC | i | H | n1 |
| Hexadecimal: | 1B | 69 | 48 | n1 |

Parameters

n1=0, 1

Description

- Select enable or disable of recovery print.
 - n1=00h: Disable recovery print
 - n1=01h: Enable recovery print
- This command is a dynamic command.

Remarks

- Invalid if n1 is a value outside of the allowable range

5.10 Advanced static commands

ESC iXQ2 Select default character style

| | | | | | | | | |
|--------------|-----|----|----|----|----|-----|-----|----|
| ASCII: | ESC | i | X | Q | 2 | 01h | 00h | n1 |
| Hexadecimal: | 1B | 69 | 58 | 51 | 32 | 01 | 00 | n1 |

Parameters

00h≤n1≤04h

Description

- Selects the default character style.
 - n1=00h: None (normal characters) (*Manufacturer's default)
 - n1=01h: Bold
 - n1=02h: Outline
 - n1=03h: Shadow
 - n1=04h: Shadow and outline
- This command is a static command.

Remarks

- Invalid if n1 is a value other than 00h through 04h

ESC iXQ1 Retrieve default character style

| | | | | | | | |
|--------------|-----|----|----|----|----|-----|-----|
| ASCII: | ESC | i | X | Q | 1 | 00h | 00h |
| Hexadecimal: | 1B | 69 | 58 | 51 | 31 | 00 | 00 |

Parameters

None

Description

- The default character style setting is returned as 3-byte data.

| | |
|-----|---|
| [1] | 01h (Fixed) |
| [2] | 00h (Fixed) |
| [3] | Setting 00h: None (normal characters) 01h: Bold 02h: Outline 03h: Shadow 04h: Shadow and outline |

- The retrieved value is a value specified by a static command.

ESC iXk2 Select default font

| | | | | | | | | |
|--------------|-----|----|----|----|----|-----|-----|----|
| ASCII: | ESC | i | X | k | 2 | 01h | 00h | n1 |
| Hexadecimal: | 1B | 69 | 58 | 6B | 32 | 01 | 00 | n1 |

Parameters

00h≤n1≤05h, 08h≤n1≤0Bh

Description

- Selects the default font.
 - n1=00h: Gothic (bitmap)
 - n1=01h: Letter Gothic Bold (bitmap) (*Manufacturer's default)
 - n1=02h: Brussels (bitmap)
 - n1=03h: Helsinki (bitmap)
 - n1=04h: San Diego (bitmap)
 - n1=05h: Brougham (bitmap)
 - n1=08h: Gothic (outline)
 - n1=09h: Letter Gothic (outline)
 - n1=0Ah: Brussels (outline)
 - n1=0Bh: Helsinki (outline)
- This command is a static command.

Remarks

- Invalid if n1 is a value outside of the allowable range
- Proportional pitched Gothic is forced to be selected when a character assigned from 0x80 to 0xFF in the Japanese character code table is used. If the character size is set to 48dot, it is not printed.
- Please refer to [Appendix B: Specifications](#).

ESC iXk1 Retrieve default font

| | | | | | | | |
|--------------|-----|----|----|----|----|-----|-----|
| ASCII: | ESC | i | X | k | 1 | 00h | 00h |
| Hexadecimal: | 1B | 69 | 58 | 6B | 31 | 00 | 00 |

Parameters

None

Description

- The default font setting is returned as 3-byte data.

| | |
|-----|--|
| [1] | 01h (Fixed) |
| [2] | 00h (Fixed) |
| [3] | Setting 00h: Gothic (bitmap) 01h: Letter Gothic Bold (bitmap) 02h: Brussels (bitmap) 03h: Helsinki (bitmap) 04h: San Diego (bitmap) 05h: Brougham (bitmap) 08h: Gothic (outline) 09h: Letter Gothic (outline) 0Ah: Brussels(outline) 0Bh: Helsinki (outline) |

- The retrieved value is a value specified by a static command.

ESC iXX2 Specify default character size

| | | | | | | | | | |
|--------------|-----|----|----|----|----|-----|-----|----|----|
| ASCII: | ESC | i | X | X | 2 | 02h | 00h | n1 | n2 |
| Hexadecimal: | 1B | 69 | 58 | 58 | 32 | 02 | 00 | n1 | n2 |

Parameters

00h≤n1≤FFh, 00h≤n2≤01h

Description

- Specifies the default character size.
n1+(n2*256): Default character size (dots)
- The following settings (dots) are valid.
The maximum valid setting is n=400.
*The manufacturer's default is 24.
- This command is a static command.

Remarks

- Invalid if the setting is a value outside of the allowable range

ESC iXX1 Retrieve default character size

| | | | | | | | |
|--------------|-----|----|----|----|----|-----|-----|
| ASCII: | ESC | i | X | X | 1 | 00h | 00h |
| Hexadecimal: | 1B | 69 | 58 | 58 | 31 | 00 | 00 |

Parameters

None

Description

- The default character size setting is returned as 4-byte data.

| | |
|--------|--|
| [1] | 02h (Fixed) |
| [2] | 00h (Fixed) |
| [3, 4] | n1 n2 settings n1+(n2*256): Default character size (dots) |

- The retrieved value is a value specified by a static command.

ESC iX32 Specify default line feed

| | | | | | | | | | |
|--------------|-----|----|----|----|----|-----|-----|----|----|
| ASCII: | ESC | i | X | 3 | 2 | 02h | 00h | n1 | n2 |
| Hexadecimal: | 1B | 69 | 58 | 33 | 32 | 02 | 00 | n1 | n2 |

Parameters

00h≤n1≤FFh, 00h≤n2≤02h

Description

- Specifies the default line feed.
n1+(n2*256): Default line feed (dots)
*The manufacturer's default is 32.
- Specified length is from 0 to 2 inches.
- This command is a static command.

Remarks

- Invalid if the setting is a value outside of the allowable range

ESC iX31 Retrieve default line feed

| | | | | | | | |
|--------------|-----|----|----|----|----|-----|-----|
| ASCII: | ESC | i | X | 3 | 1 | 00h | 00h |
| Hexadecimal: | 1B | 69 | 58 | 33 | 31 | 00 | 00 |

Parameters

None

Description

- The default line feed setting is returned as 4-byte data.

| | |
|--------|---|
| [1] | 02h (Fixed) |
| [2] | 00h (Fixed) |
| [3, 4] | n1 n2 settings n1+(n2*256): Default line feed (dots) |

- The retrieved value is a value specified by a static command.

ESC iXA2 Select default alignment

| | | | | | | | | |
|--------------|-----|----|----|----|----|-----|-----|----|
| ASCII: | ESC | i | X | A | 2 | 01h | 00h | n1 |
| Hexadecimal: | 1B | 69 | 58 | 41 | 32 | 01 | 00 | n1 |

Parameters

00h≤n1≤02h

Description

- Selects the default alignment.
 - n1=00h: Left alignment (*Manufacturer's default)
 - n1=01h: Center alignment
 - n1=02h: Right alignment
- This command is a static command.

Remarks

- Invalid if n1 is a value outside of the allowable range

ESC iXA1 Retrieve default alignment

| | | | | | | | |
|--------------|-----|----|----|----|----|-----|-----|
| ASCII: | ESC | i | X | A | 1 | 00h | 00h |
| Hexadecimal: | 1B | 69 | 58 | 41 | 31 | 00 | 00 |

Parameters

None

Description

- The default alignment setting is returned as 3-byte data.

| | |
|-----|---|
| [1] | 01h (Fixed) |
| [2] | 00h (Fixed) |
| [3] | Setting 00h: Left alignment 01h: Center alignment 02h: Right alignment |

- The retrieved value is a value specified by a static command.

ESC iX(2 Specify default page length

| | | | | | | | | | |
|--------------|-----|----|----|----|----|-----|-----|----|----|
| ASCII: | ESC | i | X | (| 2 | 02h | 00h | n1 | n2 |
| Hexadecimal: | 1B | 69 | 58 | 28 | 32 | 02 | 00 | n1 | n2 |

Parameters

00h≤n1≤FFh, 00h≤n2≤6Bh (for 203dpi printers)

00h≤n1≤FFh, 00h≤n2≤8Ch (for 300dpi printers)

Description

- Specifies the default page length.
n1+(n2*256): Default page length (dots)
*A default page length 0 indicates the Auto setting.
*The manufacturer's default is 0.
- Specified length is from 1 to 120 inches.
- This command is a static command.

Remarks

- Invalid if the setting is a value outside of the allowable range

ESC iX(1 Retrieve default page length

| | | | | | | | |
|--------------|-----|----|----|----|----|-----|-----|
| ASCII: | ESC | i | X | (| 1 | 00h | 00h |
| Hexadecimal: | 1B | 69 | 58 | 28 | 31 | 00 | 00 |

Parameters

None

Description

- The default page length setting is returned as 4-byte data.

| | |
|--------|--|
| [1] | 02h (Fixed) |
| [2] | 00h (Fixed) |
| [3, 4] | n1 n2 settings n1+(n2*256): Default page length (dots) *A default page length of 0 indicates the Auto setting. |

- The retrieved value is a value specified by a static command.

ESC iXL2 Select default landscape orientation

| | | | | | | | | |
|--------------|-----|----|----|----|----|-----|-----|----|
| ASCII: | ESC | i | X | L | 2 | 01h | 00h | n1 |
| Hexadecimal: | 1B | 69 | 58 | 4C | 32 | 01 | 00 | n1 |

Parameters

00h≤n1≤01h

Description

- Selects the default landscape orientation setting.
 - n1=00h: Cancel landscape orientation (*Manufacturer's default)
 - n1=01h: Apply landscape orientation
- This command is a static command.

Remarks

- Invalid if n1 is a value outside of the allowable range

ESC iXL1 Retrieve default landscape orientation

| | | | | | | | |
|--------------|-----|----|----|----|----|-----|-----|
| ASCII: | ESC | i | X | L | 1 | 00h | 00h |
| Hexadecimal: | 1B | 69 | 58 | 4C | 31 | 00 | 00 |

Parameters

None

Description

- The default landscape orientation setting is returned as 3-byte data.

| | |
|-----|--|
| [1] | 01h (Fixed) |
| [2] | 00h (Fixed) |
| [3] | Setting 00h: Cancel landscape orientation 01h: Apply landscape orientation |

- The retrieved value is a value specified by a static command.

ESC iXj2 Select default international character set

| | | | | | | | | |
|--------------|-----|----|----|----|----|-----|-----|----|
| ASCII: | ESC | i | X | j | 2 | 01h | 00h | n1 |
| Hexadecimal: | 1B | 69 | 58 | 6A | 32 | 01 | 00 | n1 |

Parameters

00h≤n1≤0Dh, 40h

Description

- Selects the default international character set.
 - n1=00h: U.S.A. (*Manufacturer's default)
 - n1=01h: France
 - n1=02h: Germany
 - n1=03h: U.K.
 - n1=04h: Denmark I
 - n1=05h: Sweden
 - n1=06h: Italy
 - n1=07h: Spain I
 - n1=08h: Japan
 - n1=09h: Norway
 - n1=0Ah: Denmark II
 - n1=0Bh: Spain II
 - n1=0Ch: Latin America
 - n1=0Dh: South Korea
 - n1=40h: Legal
- This command is a static command.

Remarks

- Invalid if n1 is a value outside of the allowable range

ESC iXj1 Retrieve default international character set

| | | | | | | | |
|--------------|-----|----|----|----|----|-----|-----|
| ASCII: | ESC | i | X | j | 1 | 00h | 00h |
| Hexadecimal: | 1B | 69 | 58 | 6A | 31 | 00 | 00 |

Parameters

None

Description

- The default international character set setting is returned as 3-byte data.

| | |
|-----|--|
| [1] | 01h (Fixed) |
| [2] | 00h (Fixed) |
| [3] | Setting 00h: U.S.A. 01h: France 02h: Germany 03h: U.K. 04h: Denmark I 05h: Sweden 06h: Italy 07h: Spain I 08h: Japan 09h: Norway 0Ah: Denmark II 0Bh: Spain II 0Ch: Latin America 0Dh: South Korea 40h: Legal |

- The retrieved value is a value specified by a static command.

ESC iXm2 Select default character code set

| | | | | | | | | |
|--------------|-----|----|----|----|----|-----|-----|----|
| ASCII: | ESC | i | X | m | 2 | 01h | 00h | n1 |
| Hexadecimal: | 1B | 69 | 58 | 6D | 32 | 01 | 00 | n1 |

Parameters

00h≤n1≤04h

Description

- Selects the default character code set.
 - n1=00h: Standard character code set (*Manufacturer's default)
 - n1=01h: Eastern European character code set
 - n1=02h: Western European character code set
 - n1=03h: Reserved
 - n1=04h: Japanese character code set
- This command is a static command.

Remarks

- Invalid if n is a value outside of the allowable range.

ESC iXm1 Retrieve default character code set

| | | | | | | | |
|--------------|-----|----|----|----|----|-----|-----|
| ASCII: | ESC | i | X | m | 1 | 00h | 00h |
| Hexadecimal: | 1B | 69 | 58 | 6D | 31 | 00 | 00 |

Parameters

None

Description

- The default character code set setting is returned as 3-byte data.

| | |
|-----|--|
| [1] | 01h (Fixed) |
| [2] | 00h (Fixed) |
| [3] | Setting 00h: Standard character code set 01h: Eastern European character code set 02h: Western European character code set 03h: Reserved 04h: Japanese character code set |

- The retrieved value is a value specified by a static command.

ESC iXd2 Specify recovery setting

| | | | | | | | | |
|--------------|-----|----|----|----|----|-----|-----|----|
| ASCII: | ESC | i | X | d | 2 | 01h | 00h | n1 |
| Hexadecimal: | 1B | 69 | 58 | 64 | 32 | 01 | 00 | n1 |

Parameters

00h≤n1≤01h

Description

- Select enable or disable of recovery print.
n1=00h: Disable recovery print
n1=01h: Enable recovery print
- This command is a static command.
- Manufacturer's default:
00h Disable recovery print: TD-2XXX
01h Enable recovery print: RJ-4XXX, RJ-3XXX, RJ-2XXX, TD-4XXX

Remarks

- Invalid if n1 is a value outside of the allowable range

ESC iXd1 Retrieve recovery setting

| | | | | | | | |
|--------------|-----|----|----|----|----|-----|-----|
| ASCII: | ESC | i | X | d | 1 | 00h | 00h |
| Hexadecimal: | 1B | 69 | 58 | 64 | 31 | 00 | 00 |

Parameters

None

Description

- Return a current recovery setting as 3 Bytes data.

| | |
|-----|--|
| [1] | 01h (Fixed) |
| [2] | 00h (Fixed) |
| [3] | Setting 00h: Disable recovery print 01h: Enable recovery print |

- The retrieved value is a value specified by a static command.

ESC iXv2 (0Ch) Specify recovery count

| | | | | | | | | | | |
|--------------|-----|----|----|----|----|-----|-----|-----|-----|----|
| ASCII: | ESC | i | X | v | 2 | 03h | 00h | 00h | 0Ch | n1 |
| Hexadecimal: | 1B | 69 | 58 | 76 | 32 | 03 | 00 | 00 | 0C | n1 |

Parameters

n1: 00h, 01h

Description

- Select the recovery print count.
 - n1=00h: Recovery count: 1
 - n1=01h: Recovery count: Unlimited
- The default value is 00h (1).
 - This command is a static command.

Command example

- For specifying the recovery print count to unlimited.

Since the value will be n1=01h, the command will be as follows.

```
ESC i X v 2 03h 00h 00h 0Ch 01h
(1Bh 69h 58h 76h 32h 03h 00h 00h 0Ch 01h)
```

ESC iXv1 (0Ch) Retrieve recovery count

| | | | | | | | | | | |
|--------------|-----|----|----|----|----|-----|-----|-----|-----|-----|
| ASCII: | ESC | i | X | v | 1 | 03h | 00h | 00h | 0Ch | 00h |
| Hexadecimal: | 1B | 69 | 58 | 76 | 31 | 03 | 00 | 00 | 0C | 00 |

Parameters

None

Description

- Retrieve a recovery count setting value.
- 3 bytes of data are returned from the main unit.
 - [1]: 01h (Fixed)
 - [2]: 00h (Fixed)
 - [3]: Setting values
 - 00h: Recovery count: 1
 - 01h: Recovery count: Unlimited
- The retrieved value is a value set by a static command.

Command example

- For when setting the recovery print count to 1.

| | |
|-----------------|---|
| Code: | ESC i X v 1 03h 00h 00h 0Ch 00h |
| | (1Bh 69h 58h 76h 31h 03h 00h 00h 0Ch 00h) |
| Returned value: | 01h 00h 00h |

ESC iXE2 Specify barcode margin setting

| | | | | | | | | |
|--------------|-----|----|----|----|----|-----|-----|----|
| ASCII: | ESC | i | X | E | 2 | 01h | 00h | n1 |
| Hexadecimal: | 1B | 69 | 58 | 45 | 32 | 01 | 00 | n1 |

Parameters

00h≤n1≤01h

Description

- Select an existence of barcode margin.
n1=00h: No margin
n1=01h: Add margin (*Manufacturer's default)
- This command is a static command.

Remarks

- Invalid if n1 is a value outside of the allowable range

ESC iXE1 Retrieve barcode margin setting

| | | | | | | | |
|--------------|-----|----|----|----|----|-----|-----|
| ASCII: | ESC | i | X | E | 1 | 00h | 00h |
| Hexadecimal: | 1B | 69 | 58 | 45 | 31 | 00h | 00h |

Parameters

None

Description

- Return a barcode margin setting as 3 Bytes data.

| | |
|-----|--|
| [1] | 01h (Fixed) |
| [2] | 00h (Fixed) |
| [3] | Setting 00h: No margin 01h: Add margin |

- The retrieved value is a value specified by a static command.

ESC iX 2 (00h) Specify line print setting

| | | | | | | | | | | |
|--------------|-----|----|----|----|----|-----|-----|-----|-----|----|
| ASCII: | ESC | i | X | _ | 2 | 03h | 00h | 00h | 00h | n1 |
| Hexadecimal: | 1B | 69 | 58 | 5F | 32 | 03 | 00 | 00 | 00 | n1 |

Parameters

00h≤n1≤FFh

Description

- Select a line print enable/disable setting.
 - n1=00h: Enable line print (default)
 - n1=01h~FFh: Disable line print
- This command is a static command.
- This command is available only with continuous length tape.

ESC iX 1 (00h) Retrieve line print setting

| | | | | | | | | | |
|--------------|-----|----|----|----|----|-----|-----|-----|-----|
| ASCII: | ESC | i | X | _ | 1 | 02h | 00h | 00h | 00h |
| Hexadecimal: | 1B | 69 | 58 | 5F | 31 | 02 | 00 | 00 | 00 |

Parameters

None

Description

- Return a line print enable/disable setting as 3 Bytes data.

| | |
|-----|--|
| [1] | 01h (Fixed) |
| [2] | 00h (Fixed) |
| [3] | Setting 00h: Line print enabled 01h~FFh: Line print disabled |

- The retrieved value is a value specified by a static command.

ESC iX 2 (01h) Specify line print timeout setting

| | | | | | | | | | | |
|--------------|-----|----|----|----|----|-----|-----|-----|-----|----|
| ASCII: | ESC | i | X | _ | 2 | 03h | 00h | 00h | 01h | n1 |
| Hexadecimal: | 1B | 69 | 58 | 5F | 32 | 03 | 00 | 00 | 01 | n1 |

Parameters

00h≤n1≤FFh

Description

- Set a time for print start after receiving line feed command..
n1=00h: 1000msec (default)
n1=01h~FFh: Specified value X 100msec
- This command only works when line print is enabled.
- This command is a static command.

ESC iX 1 (01h) Retrieve line print timeout setting

| | | | | | | | | | |
|--------------|-----|----|----|----|----|-----|-----|-----|-----|
| ASCII: | ESC | i | X | _ | 1 | 02h | 00h | 00h | 01h |
| Hexadecimal: | 1B | 69 | 58 | 5F | 31 | 02 | 00 | 00 | 01 |

Parameters

None

Description

- Return a time for print start after receiving line feed command as 3 Bytes data.

| | |
|-----|--|
| [1] | 01h (Fixed) |
| [2] | 00h (Fixed) |
| [3] | Setting 00h: 1000msec 01h~FFh: Retrieved value X 100msec |

- The retrieved value is a value specified by a static command.

ESC i DC1 SQ(01h) Specify self-printing QR code content

| | | | | | | | | | |
|--------------|-----|----|-----|----|----|-----|----|----|------|
| ASCII: | ESC | i | DC1 | S | Q | 01h | n1 | n2 | data |
| Hexadecimal: | 1B | 69 | 11 | 53 | 51 | 01 | n1 | n2 | data |

Parameters

$00h \leq n1 \leq 5Ah$

n2: 00h

Description

- Set the QR code content included in self-printing.
 - n1: length of the content set in the QR code (up to 90 bytes)
 - data: content set in the QR code
- This command is a static command.

ESC i DC1 SQ(00h) Retrieve self-printing QR code content

| | | | | | | | | |
|--------------|-----|----|-----|----|----|-----|-----|-----|
| ASCII: | ESC | i | DC1 | S | Q | 00h | 00h | 00h |
| Hexadecimal: | 1B | 69 | 11 | 53 | 51 | 00 | 00 | 00 |

Parameters

None

Description

- The self printing QR code content setting value is returned with the following data.

| | |
|---------------|--|
| [1] | 00h (Fixed) |
| [2] | 01h (Fixed) |
| [3] | Command reception response 00h: command reception OK 01h: command reception NG |
| [4] | Length of the content set in the QR code |
| [5] | 00h (Fixed) |
| [6] and after | Content set in the QR code |

- The retrieved value is a value specified by a static command.

ESC i DC1 SR(01h) Select setting change lock

| | | | | | | | | | |
|--------------|-----|----|-----|----|----|-----|----|----|----|
| ASCII: | ESC | i | DC1 | S | Q | 01h | n1 | n2 | n3 |
| Hexadecimal: | 1B | 69 | 11 | 53 | 52 | 01 | n1 | n2 | n3 |

Parameters

- n1: 01h
- n2: 00h
- n3: 00h or FFh

Description

- Prohibit changing settings and rewriting transfer data.
 - n3=00h: Cancel the prohibition of setting change
 - n3=FFh: Prohibit setting change
- This command is a static command.

ESC i DC1 SR(00h) Retrieve setting change lock

| | | | | | | | | |
|--------------|-----|----|-----|----|----|-----|-----|-----|
| ASCII: | ESC | i | DC1 | S | Q | 00h | 00h | 00h |
| Hexadecimal: | 1B | 69 | 11 | 53 | 52 | 00 | 00 | 00 |

Parameters

None

Description

- The setting change lock setting value is returned as 6-byte data.

| | |
|-----|--|
| [1] | 00h (Fixed) |
| [2] | 01h (Fixed) |
| [3] | Command reception response 00h: command reception OK 01h: command reception NG |
| [4] | 01h (Fixed) |
| [5] | 00h (Fixed) |
| [6] | 00h: Cancel prohibition FFh: Prohibit |

- The retrieved value is a value specified by a static command.

Appendix A: Supported Printers

| Series | Model |
|---------|-------------|
| RJ-4XXX | RJ-4230B |
| | RJ-4250WB |
| RJ-3XXX | RJ-3230B |
| | RJ-3250WB |
| RJ-2XXX | RJ-2030 |
| | RJ-2050 |
| | RJ-2140 |
| | RJ-2150 |
| TD-4XXX | TD-4410D |
| | TD-4420DN |
| | TD-4510D |
| | TD-4520DN |
| | TD-4550DNWB |
| | TD-4210D |
| TD-2XXX | TD-2020 |
| | TD-2120N |
| | TD-2130N |

Appendix B: Specifications

RJ-4XXX series:

| Model | | RJ-4230B | RJ-4250WB | |
|--------------------------|---------------------------|---|--|--|
| Printing | Printing method | Raster ESC/P <u>P-touch Template</u> CPCL Page Print emulation CPCL Line Print emulation | | |
| | Maximum print length | 3 m | | |
| | Resolution (dpi) | 203 dpi × 203 dpi | | |
| | Maximum width (in dots) | 832 dots | | |
| | Text | Bitmap Fonts | Letter Gothic Bold(16/24/32dots), Helsinki(16/24/32dots), Gothic(16/24/32dots) | |
| | | Outline Fonts | Letter Gothic, Brussels, Helsinki, Gothic (Maximum 400 dots) | |
| | | Character style | None, Italic, Bold, Double-strike | |
| | | Underline | Supported | |
| | | Character width | Pica pitch, Elite pitch, Micron pitch | |
| | | Horizontal alignment | Left, Center, Right | |
| | | Rotate | — | |
| | Bar-code | Types | CODE39, ITF (I-2/5), EAN-13, EAN-8, UPC-A, UPC-E, CODABAR, CODE128, GS1-128 (UCC/EAN-128), GS1 Databar(Omni, Truncated, Stacked, Stacked Omni, Limited, Expanded, Expanded Stacked), POSTNET, ntelligent Mail Barcode, CODE93, UPC/EAN EXTENSION, MSI/Plessey, QR Code, PDF417, Data Matrix, MaxiCode, Aztec, | |
| | | Width | Large, Medium, Small, Extra Small | |
| | FlashROM (user available) | | 42MB | |
| Communication Interfaces | | USB, Bluetooth | USB, Bluetooth, WLAN | |
| Options | | - | | |

Settings that appear in **bold** and underlined are the default settings.

RJ-3XXX series:

| Model | | RJ-3230B | RJ-3250WB | |
|--------------------------|---------------------------|---|--|--|
| Printing | Printing method | Raster ESC/P <u>P-touch Template</u> CPCL Page Print emulation CPCL Line Print emulation | | |
| | Maximum print length | 3 m | | |
| | Resolution (dpi) | 203 dpi × 203 dpi | | |
| | Maximum width (in dots) | 576 dots | | |
| | Text | Bitmap Fonts | Gothic(16/24/32dots), Letter Gothic Bold(16/24/32/48dots), Helsinki(16/24/32/48dots), Brussels(24/32/48dots), San Diego(24/32/48dots), Brougham(24/32/48dots) | |
| | | Outline Fonts | Gothic, Letter Gothic, Brussels, Helsinki (Maximum 400 dots) | |
| | | Character style | None, Italic, Bold, Double-strike | |
| | | Underline | Supported | |
| | | Character width | Pica pitch, Elite pitch, Micron pitch | |
| | | Horizontal alignment | Left, Center, Right | |
| | | Rotate | — | |
| | Bar-code | Types | CODE39, ITF (I-2/5), EAN-13, EAN-8, UPC-A, UPC-E, CODABAR, CODE128, GS1-128 (UCC/EAN-128), GS1 Databar(Omni, Truncated, Stacked, Stacked Omni, Limited, Expanded, Expanded Stacked), POSTNET, Intelligent Mail Barcode, CODE93, UPC/EAN EXTENSION, MSI/Plessey, QR Code, PDF417, Data Matrix, MaxiCode, Aztec | |
| | | Width | Large, Medium, Small, Extra Small | |
| | FlashROM (user available) | | 42MB | |
| Communication Interfaces | | USB Bluetooth Ethernet (Option) | USB Bluetooth WLAN Ethernet (Option) | |
| Options | | Label Peeler | | |

Settings that appear in **bold** and underlined are the default settings.

RJ-2XXX series:

| Model | | RJ-2030 | RJ-2050 | RJ-2140 | RJ-2150 | |
|--------------------------|---------------------------|---|---|--------------|---------------------------|--|
| Printing | Printing method | Raster ESC/P <u>P-touch Template</u> CPCL Page Print emulation CPCL Line Print emulation | | | | |
| | Maximum print length | 1 m | | | | |
| | Resolution (dpi) | 203 dpi × 203 dpi | | | | |
| | Maximum width (in dots) | 432 dots | | | | |
| | Text | Bitmap Fonts | Gothic(16/24/32dots), Letter Gothic Bold(16/24/32dots), Helsinki(16/24/32dots) | | | |
| | | Outline Fonts | Gothic, Letter Gothic, Brussels, Helsinki (Maximum 400 dots) | | | |
| | | Character style | None, Italic, Bold, Double-strike | | | |
| | | Underline | Supported | | | |
| | | Character width | Pica pitch, Elite pitch, Micron pitch | | | |
| | | Horizontal alignment | Left, Center, Right | | | |
| | | Rotate | — | | | |
| | Bar-code | Types | CODE39, ITF (I-2/5), EAN-13, EAN-8, UPC-A, UPC-E, CODABAR, CODE128, GS1-128 (UCC/EAN-128), GS1 Databar(Omni, Truncated, Stacked, Stacked Omni, Limited, Expanded, Expanded Stacked), POSTNET, CODE93, UPC/EAN EXTENSION, MSI/Plessey, QR Code, PDF417, Data Matrix, MaxiCode, Aztec | | | |
| | | Width | Large, Medium, Small, Extra Small | | | |
| | FlashROM (user available) | | 12MB | | | |
| Communication Interfaces | | USB, Bluetooth | USB, Bluetooth WLAN | USB, WLAN | USB, Bluetooth WLAN | |
| Options | | - | | | | |

Settings that appear in **bold** and underlined are the default settings.

TD-4XXX series:

| Model | | TD-4410D | TD-4420D N | TD-4210D | TD-4510D | TD-4520D N | 4550DNW B | |
|---------------------------|-------------------------|---|--|----------------|-------------------|----------------------------|---|--|
| Printing | Printing method | Raster ESC/P <u>P-touch Template</u> CPCL Page Print emulation CPCL Line Print emulation EPL emulation DPL emulation | | | | | | |
| | Maximum print length | 3 m | | | | | | |
| | Resolution (dpi) | 203 dpi × 203 dpi | | | 300 dpi × 300 dpi | | | |
| | Maximum width (in dots) | 1280 dots | | | | | | |
| | Text | Bitmap Fonts | Gothic(16/24/32dots), Letter Gothic Bold(16/24/32/48dots), Helsinki(16/24/32/48dots), Brussels(24/32/48dots), San Diego(24/32/48dots), Brougham(24/32/48dots) | | | | | |
| | | Outline Fonts | Gothic, Letter Gothic, Brussels, Helsinki (Maximum 400 dots) | | | | | |
| | | Character style | None, Italic, Bold, Double-strike | | | | | |
| | | Underline | Supported | | | | | |
| | | Character width | Pica pitch, Elite pitch, Micron pitch | | | | | |
| | | Horizontal alignment | Left, Center, Right | | | | | |
| | | Rotate | — | | | | | |
| | Bar-code | Types | CODE39, ITF (I-2/5), EAN-13, EAN-8, UPC-A, UPC-E, CODABAR, CODE128, GS1-128 (UCC/EAN-128), GS1 Databar(Omni, Truncated, Stacked, Stacked Omni, Limited, Expanded, Expanded Stacked), POSTNET, Intelligent Mail Barcode, CODE93, UPC/EAN EXTENSION, MSI/Plessey, QR Code, PDF417, Data Matrix, MaxiCode, Aztec | | | | | |
| | | Width | Large, Medium, Small, Extra Small | | | | | |
| FlashROM (user available) | | 40MB | | | | | | |
| Communication Interfaces | | USB RS-232C | USB RS-232C Ethernet | USB RS-232C | USB RS-232C | USB RS-232C Ethernet | USB RS-232C Ethernet Bluetooth WLAN USB-HOST | |
| Options | | Cutter, Label Peeler | | | | | | |

Settings that appear in **bold** and underlined are the default settings.

TD-2XXX series:

| Model | | TD-2020 | TD-2120N | TD-2130N | |
|---------------------------|-------------------------|---|---|-----------------|--|
| Printing | Printing method | Raster ESC/P <u>P-touch Template</u> CPCL Page Print emulation CPCL Line Print emulation | | | |
| | Maximum print length | 1 m | | | |
| | Resolution (dpi) | 203 dpi × 203 dpi | | 300dpi x 300dpi | |
| | Maximum width (in dots) | 448 dots | | 672 dots | |
| | Text | Bitmap Fonts | Gothic(16/24/32dots), Letter Gothic Bold(16/24/32dots), Helsinki(16/24/32dots) | | |
| | | Outline Fonts | Gothic, Letter Gothic, Brussels, Helsinki (Maximum 400 dots) | | |
| | | Character style | None, Italic, Bold, Double-strike | | |
| | | Underline | Supported | | |
| | | Character width | Pica pitch, Elite pitch, Micron pitch | | |
| | | Horizontal alignment | Left, Center, Right | | |
| | | Rotate | — | | |
| | Bar-code | Types | CODE39, ITF (I-2/5), EAN-13, EAN-8, UPC-A, UPC-E, CODABAR, CODE128, GS1-128 (UCC/EAN-128), GS1 Databar(Omni, Truncated, Stacked, Stacked Omni, Limited, Expanded, Expanded Stacked), POSTNET, CODE93, UPC/EAN EXTENSION, MSI/Plessey, QR Code, PDF417, Data Matrix, MaxiCode, Aztec | | |
| | | Width | Large, Medium, Small, Extra Small | | |
| FlashROM (user available) | | 6MB | | | |
| Communication Interfaces | | USB RS-232C | USB RS-232C Ethernet Bluetooth (Option) WLAN (Option) | | |
| Options | | - | Battery, Label Peeler | | |

Settings that appear in **bold** and underlined are the default settings.

Appendix C: Character Code Tables

Character code tables

(1) Windows1252 (Western Europe)

| | 0 | 1 | 2 | 3 | 4 | 5 | 6 | 7 | 8 | 9 | A | B | C | D | E | F |
|---|---|---|----|---|---|---|---|-----|-----|---|---------------------------|---------------------------|---|---|---|---|
| 0 | | | SP | 0 | @ | P | | p | € | | | ° | À | Ð | à | ð |
| 1 | | | ! | 1 | A | Q | a | q | ~ | ' | i | ± | Á | Ñ | á | ñ |
| 2 | | | " | 2 | B | R | b | r | , | ' | ¢ | ² | Â | Ò | â | ò |
| 3 | | | # | 3 | C | S | c | s | f | " | £ | ³ | Ã | Ó | ã | ó |
| 4 | | | \$ | 4 | D | T | d | t | , | " | ¤ | ' | Ä | Ô | ä | ô |
| 5 | | | % | 5 | E | U | e | u | ... | • | ¥ | µ | Å | Õ | å | õ |
| 6 | | | & | 6 | F | V | f | v | † | - | | ¶ | Æ | Ö | æ | ö |
| 7 | | | ' | 7 | G | W | g | w | ‡ | — | § | · | Ç | × | ç | ÷ |
| 8 | | | (| 8 | H | X | h | x | ^ | ~ | ¨ | ¸ | È | Ø | è | ø |
| 9 | | |) | 9 | I | Y | i | y | ‰ | ™ | © | ¹ | É | Ù | é | ù |
| A | | | * | : | J | Z | j | z | Š | š | ^a ₋ | ^o ₋ | Ê | Ú | ê | ú |
| B | | | + | ; | K | [| k | { | < | > | « | » | Ë | Û | ë | û |
| C | | | , | < | L | \ | l | | Œ | œ | ¬ | ¼ | Ì | Ü | ì | ü |
| D | | | - | = | M |] | m | } | | | - | ½ | Í | Ý | í | ý |
| E | | | . | > | N | ^ | n | ~ | Ž | ž | ® | ¾ | Î | Þ | î | þ |
| F | | | / | ? | O | _ | o | DEL | | ÿ | ¯ | ¿ | Ï | ß | ï | ÿ |

Note

- " ■ " indicates that a space is printed.
- " ■ " indicates that the character will switch when the international character set is changed.

(2) Windows1250 (Eastern Europe)

| | 0 | 1 | 2 | 3 | 4 | 5 | 6 | 7 | 8 | 9 | A | B | C | D | E | F |
|---|---|---|----|---|---|---|---|-----|-----|---|---|---|---|---|---|---|
| 0 | | | SP | 0 | @ | P | ` | p | € | ť | | ° | Ř | Đ | ř | ď |
| 1 | | | ! | 1 | A | Q | a | q | À | ‘ | ˘ | ± | Á | Ń | á | ń |
| 2 | | | " | 2 | B | R | b | r | , | ’ | ˘ | ˙ | Â | Ň | â | ň |
| 3 | | | # | 3 | C | S | c | s | ˘ | “ | Ł | ł | Ă | Ó | ă | ó |
| 4 | | | \$ | 4 | D | T | d | t | „ | ” | ¤ | ’ | Ä | Ô | ä | ô |
| 5 | | | % | 5 | E | U | e | u | ... | • | Ą | μ | Í | Õ | í | õ |
| 6 | | | & | 6 | F | V | f | v | † | – | | ¶ | Ć | Ö | ć | ö |
| 7 | | | ’ | 7 | G | W | g | w | ‡ | — | § | · | Ç | × | ç | ÷ |
| 8 | | | (| 8 | H | X | h | x | ı | | ” | ˙ | Č | Ř | č | ř |
| 9 | | |) | 9 | I | Y | i | y | ‰ | ™ | © | ą | É | Ů | é | ů |
| A | | | * | : | J | Z | j | z | Š | š | Ş | ş | Ę | Ú | ę | ú |
| B | | | + | ; | K | [| k | { | < | > | « | » | Ě | Ů | ě | ů |
| C | | | , | < | L | \ | l | | Ś | ś | ¬ | Ł | Ě | Ü | ę | ü |
| D | | | – | = | M |] | m | } | Ť | ť | – | ” | Í | Ý | í | ý |
| E | | | . | > | N | ^ | n | ~ | Ž | ž | ® | ı | Î | Ť | î | ț |
| F | | | / | ? | O | _ | o | DEL | Ž | ż | Ż | ż | Ď | ß | ď | · |

Note



"  " indicates that a space is printed.

"  " indicates that the character will switch when the international character set is changed.

(3) Brother standard

| | 0 | 1 | 2 | 3 | 4 | 5 | 6 | 7 | 8 | 9 | A | B | C | D | E | F |
|---|---|---|----|---|---|---|---|-----|---|-----|---|-----|---|---|---|---|
| 0 | | | SP | 0 | @ | P | ` | p | Ç | É | á | ☼ | L | | α | |
| 1 | | | ! | 1 | A | Q | a | q | ü | æ | í | ☼ | ⊥ | | β | ± |
| 2 | | | " | 2 | B | R | b | r | é | Æ | ó | ☼ | ⊥ | | | |
| 3 | | | # | 3 | C | S | c | s | â | ô | ú | | ⊥ | | | ¾ |
| 4 | | | \$ | 4 | D | T | d | t | ä | ö | ñ | ⊥ | — | | | |
| 5 | | | % | 5 | E | U | e | u | à | ò | Ñ | | ⊥ | | | § |
| 6 | | | & | 6 | F | V | f | v | å | û | ˆ | | | | μ | ÷ |
| 7 | | | ' | 7 | G | W | g | w | ç | ù | ˆ | | | | | |
| 8 | | | (| 8 | H | X | h | x | ê | ÿ | ¿ | © | ℒ | | | ° |
| 9 | | |) | 9 | I | Y | i | y | ë | Ö | ® | ⊥ | ⊥ | ⊥ | | . |
| A | | | * | : | J | Z | j | z | è | Ü | € | | ⊥ | ⊥ | Ω | |
| B | | | + | ; | K | [| k | { | ï | ø | ½ | ⊥ | ⊥ | ✓ | δ | |
| C | | | , | < | L | \ | l | | î | £ | ¼ | ⊥ | ⊥ | ☑ | | ³ |
| D | | | - | = | M |] | m | } | ì | ¥ | ì | TEL | = | | ∅ | ² |
| E | | | . | > | N | ^ | n | ~ | Ä | Pts | « | FAX | ⊥ | | | |
| F | | | / | ? | O | _ | o | DEL | Å | f | » | ⊥ | | □ | | |

Note

- "  " indicates that a space is printed.
- "  " indicates that the character will switch when the international character set is changed.

(4) Japanese character code set

| | 0 | 1 | 2 | 3 | 4 | 5 | 6 | 7 | 8 | 9 | A | B | C | D | E | F |
|---|---|---|----|---|---|---|---|-----|---|---|----|---|---|---|---|---|
| 0 | | | SP | 0 | @ | P | ▀ | p | ▀ | ⊥ | SP | □ | タ | ミ | □ | × |
| 1 | | | ! | 1 | A | Q | a | Q | ▀ | ⊥ | 。 | ア | チ | ム | □ | □ |
| 2 | | | " | 2 | B | R | b | R | ▀ | ⊥ | 「 | イ | ツ | メ | □ | □ |
| 3 | | | # | 3 | C | S | c | S | ▀ | ⊥ | 」 | ウ | テ | モ | □ | □ |
| 4 | | | \$ | 4 | D | T | d | T | ▀ | — | 、 | エ | ト | ヤ | □ | □ |
| 5 | | | % | 5 | E | U | e | u | ▀ | — | □ | オ | ナ | ユ | □ | □ |
| 6 | | | & | 6 | F | V | f | v | ▀ | | ヲ | カ | ニ | ヨ | □ | □ |
| 7 | | | ' | 7 | G | W | g | w | ▀ | □ | ア | キ | ヌ | ラ | □ | □ |
| 8 | | | (| 8 | H | X | h | x | | ⊥ | イ | ク | ネ | リ | ☼ | □ |
| 9 | | |) | 9 | I | Y | i | y | | ⊥ | ウ | ケ | ノ | ル | ♥ | □ |
| A | | | * | : | J | Z | j | z | | ⊥ | エ | コ | ハ | レ | ◇ | □ |
| B | | | + | ; | K | [| k | { | ▀ | ⊥ | オ | サ | ヒ | □ | ☼ | □ |
| C | | | , | < | L | \ | l | | ▀ | □ | ヤ | シ | フ | ワ | ● | □ |
| D | | | - | = | M |] | m | } | ▀ | □ | ユ | ス | ヘ | ン | ○ | □ |
| E | | | . | > | N | ^ | n | ~ | ▀ | □ | ヨ | セ | ホ | □ | / | ☼ |
| F | | | / | ? | O | _ | o | DEL | + | □ | ツ | ソ | マ | □ | \ | |

Note

"  " indicates that a space is printed.

"  " indicates that the character will switch when the international character set is changed.

A character assigned from 0x80 to 0xFF is printed as Proportional pitched Gothic.

International character set table

Corresponding characters that switch in each language when the international character set is changed

| n | | 23 | 24 | 40 | 5B | 5C | 5D | 5E | 60 | 7B | 7C | 7D | 7E |
|----|-----------------------|----|----|----|----|----|----|----|----|----|----|----|----|
| 0 | United States (U.S.A) | # | \$ | @ | [| \ |] | ^ | ` | { | | } | ~ |
| 1 | France | # | \$ | à | ° | ç | § | ^ | ` | é | ù | è | ¨ |
| 2 | Germany | # | \$ | § | Ä | Ö | Ü | ^ | ` | ä | ö | ü | ß |
| 3 | Britain (U.K.) | £ | \$ | @ | [| \ |] | ^ | ` | { | | } | ~ |
| 4 | Denmark I | # | \$ | @ | Æ | Ø | Å | ^ | ` | æ | ø | å | ~ |
| 5 | Sweden | # | ¤ | É | Ä | Ö | Å | Ü | é | ä | ö | å | ü |
| 6 | Italy | # | \$ | @ | ° | \ | é | ^ | ù | à | ò | è | ì |
| 7 | Spain I | Pt | \$ | @ | ı | Ñ | ı | ^ | ` | ¨ | ñ | } | ~ |
| 8 | Japan | # | \$ | @ | [| ¥ |] | ^ | ` | { | | } | ~ |
| 9 | Norway | # | ¤ | É | Æ | Ø | Å | Ü | é | æ | ø | å | ü |
| 10 | Denmark II | # | \$ | É | Æ | Ø | Å | Ü | é | æ | ø | å | ü |
| 11 | Spain II | # | \$ | á | ı | Ñ | ı | é | ` | ı | ñ | ó | ú |
| 12 | Latin America | # | \$ | á | ı | Ñ | ı | é | ü | ı | ñ | ó | ú |
| 13 | South Korea | # | \$ | @ | [| ₩ |] | ^ | ` | { | | } | ~ |
| 64 | Legal | # | \$ | § | ° | ' | " | ¶ | ` | © | ® | † | ™ |

Appendix D: Introducing the Brother Developer Center

Useful information for developers, such as applications, tools, SDKs as well as FAQs, are provided in the Brother Developer Center.

<https://support.brother.com/g/s/es/dev/en/index.html?navi=offall>

brother®